

# In-line Refractometer Guide

To users who have been dissatisfied  
with other types of in-line meters

At manufacturing facilities, all kinds of liquid flows through various lines of pipes, fittings, and the like.

Liquid that flows through the line is processed and blended, ultimately becoming a finished product once passes the bottling stage.

The condition and concentration of the liquid changes at each and every stage of the process.

Monitoring and managing whether the processing, blending, and concentration changes are conducted as planned allows for immediate detection of any manufacturing issues and prevents out-of-spec products, thereby resulting in accurate, reliable quality control for the utmost "safety."

Prevent Defective Products at Every Stage of the Manufacturing Process .....	B4
Application Examples .....	B6
Refractometers .....	B8
A Comparison Between Refractometers and Other Principles ....	B9
Versatile Functions and Features .....	B10
Build-up Prevention .....	B12
In-line Refractometer Lineup	
PRM™-100α DX.....	B22
PRM™-2000α DX .....	B24
CM™-800α .....	B26
CM™-ISα .....	B30
CM™-BASEα .....	B34
CM™-BASEα-Plus .....	B36
CM™-BASEα-MAX .....	B38
US-α™ .....	B42
CM™-BASEβ .....	B44
PAN™-1DC .....	B46
PRM™-TANK100α DX(FER) .....	B48
PRM™-TANK2000α DX(FER).....	B50
PRM™-TANKα(FLN) .....	B52
CM™-TANKα(FER) .....	B54
CM™-TANKα-SW(FER) .....	B56
CM™-TANKα-Urea(FER) .....	B58
CM™-INTANK .....	B60
Optional Accessories .....	B62
Customizeable Wetted Part .....	B64
Detection Section Installation Example .....	B65
Sample Inlet .....	B66
Sample Inlet List .....	B67

# Prevent Defective Products at Every Stage of the Manufacturing Process

Initial investments in in-line refractometers can avoid wasting resources

or a reputation-damaging recall!

**Example** 1,000,000 units at \$1 each ... **Save money and prevent a**

**bad batch!**

Prevent Defective Products in the Ingredient Manufacturing Process  
**\$70,000 lost**

Prevent Defective Products in the Blending Process  
**\$150,000 lost**

Prevent Defective Products in the Bottling Process  
**\$270,000 lost**

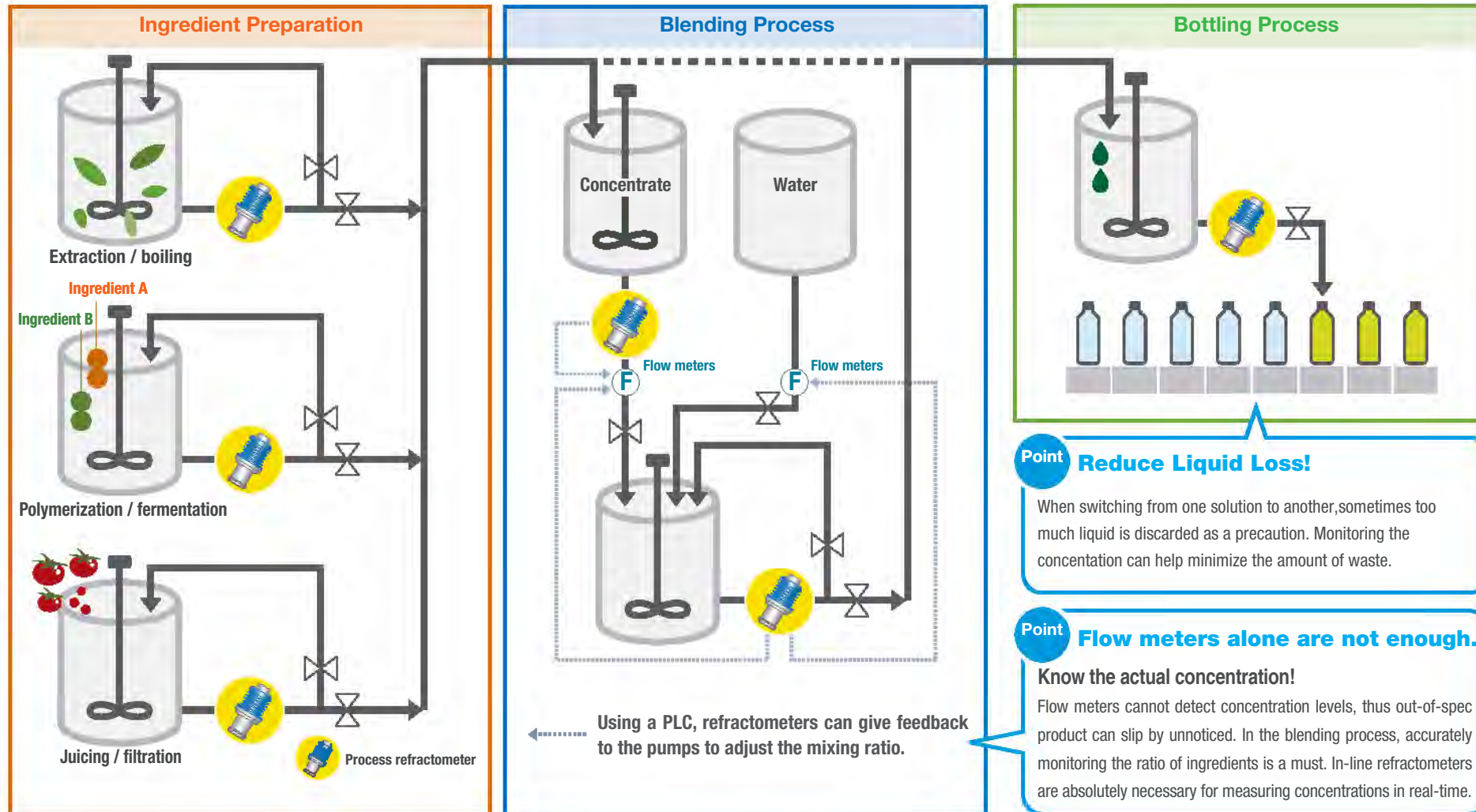

**Point Reduce Liquid Loss!**  
When switching from one solution to another, sometimes too much liquid is discarded as a precaution. Monitoring the concentration can help minimize the amount of waste.

**Point Flow meters alone are not enough.**  
**Know the actual concentration!**  
Flow meters cannot detect concentration levels, thus out-of-spec product can slip by unnoticed. In the blending process, accurately monitoring the ratio of ingredients is a must. In-line refractometers are absolutely necessary for measuring concentrations in real-time.

Each stage that a bad batch passes through costs a plant progressively more money. In this example, if an entire lot of product has to be discarded, the loss is \$270,000 in production cost, plus \$315,000 in expected profit. Furthermore, the consequences of a bad batch slipping through entirely could cost millions if a recall is required!

Causes for Defective Batches	
CIP contamination	} →
Equipment failure and incorrect operation	
Mistake during a batch test	
Defective batch from a previous stage	
Unknown cause	

In-line Refractometer Solutions	
Detects the concentration change in real-time.	} →
Fully automated measurements leave no risk for human errors.	
If you test at every production stage, you can identify a defective batch before it continues down the line.	
Discover the cause of defective batches by analyzing saved data.	

## Stay a step ahead of danger

That is the highest priority. I wanted my finished products to be consistently up to standards. Back then, we could never figure out what caused unsuitable batches. One day, we made a decision to track and keep any kind of data that could help us. That data showed us that even seemingly impossible mistakes can happen. To avoid any mistake, it is necessary to anticipate every possible mistake-causing scenario. When we track and keep the data, our factory immediately transforms into a facility that identifies the potential problems early and never produces a defective products.

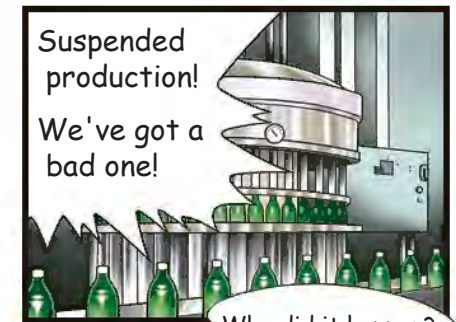

©Ishinomori Production Inc.

# Application Examples

## Ingredient Preparation



### Concentrates & syrups

Measure the Brix of the concentrate to estimate ratios for reconstitution.



### Fermentation (wine, beer, soy sauce)

Brix decreases as sugars are converted to alcohol.



### Breweries

Measure wort levels when boiling (on a bypass from the main tank).



### Dairy

Evaluate solids in condensed and evaporated milk, as well as other processed dairy products.



### Sugar cane & sugar beets

Check Brix during both extraction and refining.



### Starch & sizing liquids for paper manufacturing

Sizing liquids prevent ink from smearing on paper. The concentration must be adjusted according to the type of paper.

## Blending Process



### Beverage concentrate

Monitor and adjust Brix when evaporating to make concentrate, or diluting to single-strength.



### Sauces and seasonings

Useful in controlling ratios when combining sample from different lines.



### Polymers

Polymerization affects the refractive index of a compound; refractometers can track the progress of this reaction.



### Water-based cutting oils and lubricants

Managing concentration is essential to prevent overheating or foaming.

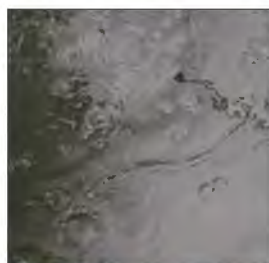

### Cleaning fluids, wastewater

Control the dilution ratio, moisture level, or contamination level of draining fluids for metal and electronic materials.



### IPA, DMF, hydrogen peroxide solutions

The concentration of strong solvents in-process can require careful monitoring to avoid potential hazards.

## Bottling Process



### Soft drinks & fruit juices



### Coffee extracts

Evaporation will raise the Brix to your target level

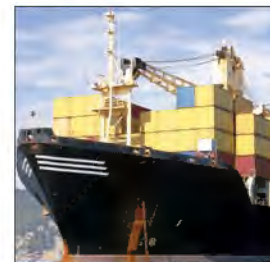

### Concentration Control of Urea in Selective Catalytic Reduction (SCR)

Monitor aqueous concentration of urea concentration used in SCR system to convert nitrogen oxide (NOx) to water and nitrogen in exhaust emission.



### Concentration Control of Long Life Coolant (LLC) for Automotives

The concentration of long life coolant is prepared and differently depending on climate and monitored at predetermined concentration.



### Sodium hydroxide solution

Sodium hydroxide and other alkaline solutions are used for wash solutions, soap manufacturing, and neutralizing acids.



### Medicines

Check the final concentration of liquid medicines to ensure compliance.

## Others

### Sugar Wastewater Check

Automate a system that redirects suitable water for recirculation or waste, based on the solids content. Ensure that wastewater sugar levels are kept at or below a set standard.

### Multiple products in one line

Minimize waste and turnaround time by noticing a concentration shift between different products.

### CIP-to-Sample

The readings can be used to infer when CIP solution has left the pipe completely. This significantly reduces the risk of producing a contaminated batch. It can also help minimize the amount of product discarded.

# Refractometers

## Principles of Refractometers

The refraction of light is a phenomenon wherein the direction that light is traveling changes as it passes through different mediums.

Through this phenomenon, we can observe as light's direction changes and the "bent" appearance of substances even in the seemingly familiar, ordinary places in our day to day lives.

For example, imagine the lens of a pair of glasses and a pool.

When looking through the lens, an object appears larger or smaller than it is in reality.

When standing inside a pool, as you peer downward from the water's surface, your legs will look shorter than they actually are.

As light moves from medium A (in this case, air) to medium B (lens and the pool's water), it refracts.

Furthermore, it is known that light's refraction changes depending on the concentration of a liquid.

The refractive index, which is a value that expresses the degree of refraction, is proportional to the density (mixture ratio) of a component.

Therefore, if there is 10g of sugar contained in 100ml of an aqueous solution and 20g of sugar contained in 100ml of an aqueous solution, the latter will have a higher refractive index value.

This difference in refractive index due to concentration variance has also been confirmed in solutions other than sucrose.

The properties of both the phenomenon known as the refraction of light and differing refractive index depending on concentration, are used as the principles of refractometers.

In addition to measuring the refractive index of a liquid, refractometers also display the concentration, converted from the refractive index.

Among refractometers, there are mainly those that utilize the transparent (refractive) system and those that utilize the reflective system for measurement.

ATAGO's PRM™ series and CM™ series are refractometers that use the reflective system. Light generated from a light source within the detection section passes through the prism, hits the sample on the wetted section (prism surface) and is reflected back once more through the prism, and is then detected by the light-receiving sensor.

This light-receiving signal is converted into the refractive index. The temperature of the sample is also simultaneously measured by the temperature sensor placed near the wetted section.

At factories that manufacture liquid products such as beverages and medicine, many processes are added to the ingredients (raw liquid) that serves as the base for the product, and there a great variety of manufacturing lines ranging from some that mix two

### Principles of Refractometers-Transparent (Refractive) System

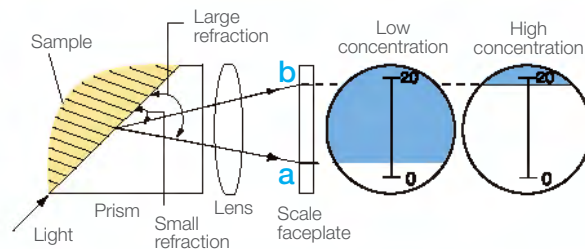

### Principles of Refractometers-Reflective System

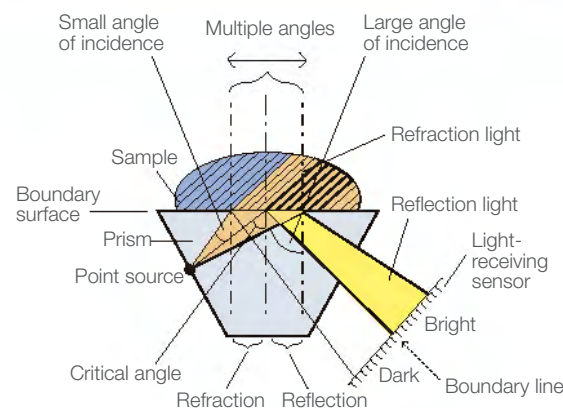

kinds of ingredients together and more, up until the final product. There are indeed all sorts of processes such as juicing, filtration, boiling, diluting, mixing (blending), and fermentation, but the concentration of the sample changes at each and every one of these stages.

For example, after the boiling stage, it is expected that the sample will become more concentrated (concentration will increase).

By monitoring the concentration, it is possible to check the sample's condition and to what extent it boiled down.

Among all these processes that the product undergoes, if only the final product is inspected, when defective products are produced, it is impossible to know at what stage of the process this occurred.

In the amount of time that passes before these defective products are discovered, a number of them have been manufactured, leading to an even greater loss.

For this reason, installing in-line refractometers at every stage of the manufacturing process and being instantly aware of the occurrence of defective products results in preventing tremendous loss before it happens.

# A Comparison Between Refractometers and Other Principles

Aside from refractometers that utilize the refraction as a measurement principle, there are many kinds of measuring instruments used in process management of liquid manufacturing lines.

## Density / Specific Gravity Meters

Density / specific gravity meters have good measurement sensitivity, and there are high accuracy models that have greater accuracy than refractometers. However, since they require a longer measurement time than refractometers, they are slow to respond to transitions such as concentration changes of liquids. Still more, they are not adept at measuring liquids that contain cloudy particulates.

## Electrical Conductivity Meters

Electrical conductivity meters measure the ease in which an electric current flows through a liquid.

Electrodes are immersed in a liquid and the electrical conductivity between the liquid and electrodes is measured. Due to the nature of this principle, measurement is limited to liquids that contain electrolytes such as brine, lye, and hydrofluoric acid.

The lower the concentration of a liquid's solid components, the higher the resolution, making electrical conductivity suitable for low concentration liquids, but as concentration increases,

accuracy decreases.

Organic types of liquids which do not contain electrolytes cannot be measured with electrical conductivity meters. As such, refractometers are ideal for measuring liquids that contain dissolvable solid components other than electrolytes.

For example, when monitoring a liquid that contains dissolved salt and sugar, an electrical conductivity meter will measure only the salt, which is an electrolyte. However, as the sugar is not an electrolyte, it will be difficult to detect. Using an in-line refractometer, the total concentration of both the salt and sugar can be measured, making in-line refractometers convenient and useful for monitoring the overall concentration of a liquid.

## Mass Flow Meters

Mass flow meters are convenient for measuring both the flow rate and the concentration of a liquid sample.

The concentration is converted from density. Low accuracy models are common.



# Versatile Functions and Features

## Compatible with a Wide Range of Temperatures

PRM™ / CM™ series

ATAGO's PRM™ series and CM™ series are compatible with a wide range of temperatures. Many kinds of samples can be measured as-is. Compatible temperatures (for PRM™-2000α DX): -35°C to 165°C. Also capable of withstanding CIP and SIP procedures. \* When switching from measurement sample to cleaning solution, the temperature difference of the solution must be within 80°C.



## Temperature Compensation

PRM™ / CM™ series

ATAGO's PRM™ series and CM™ series use the refraction of light as a measurement principle. Light's refractive index changes according to temperature, even at the same concentration of the very same substance. Thus, if the temperature of a liquid sample varies, the measurement value will change. To handle these temperature changes, the Brix scale is equipped with an automatic temperature compensation (ATC) feature according to sucrose. It is an immensely convenient and useful feature because correctly adjusted measurement values are displayed, even when measuring at different temperatures. Provided that the temperature is from 5°C to 100°C (\*1), no matter what temperature the liquid sample is at, Brix value at 20°C can be displayed. As for the PRM™ series' user-scales, temperature compensation according to the sample is possible. In addition to sucrose, the PRM™-2000α DX is equipped with temperature compensation according to high-fructose corn syrup and unsweetened beverages. \*1 CM™-BASEα: 10 to 50°C, PRM™-2000α DX: 5 to 90°C, CM™-INTANK: 10 to 40°C

**NEW** A significantly improved thermo-sensor quickly adapts to sudden temperature changes, keeping measurements stable.

More Resistant to Temperature Change!

Brix measurements stabilize more than twice as quickly as the previous model when temperature rapidly rises or drops (see image below).

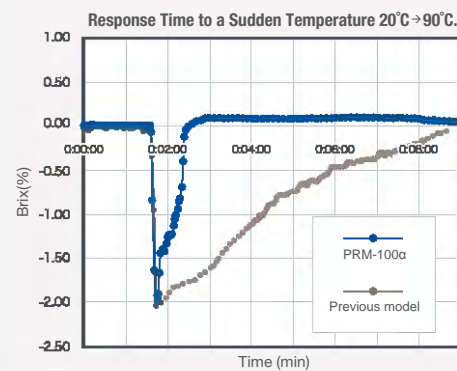

## Data Output

PRM™ / CM™ series

### Recorder output

The PRM™ series and the CM™ series (optionally available for some models) are equipped with a DC4 to 20mA power supply output feature for recorder output use. The PRM™ series and CM™-800 α outputs measurement value and temperature data and the CM™-BASEα, CM™-BASEα-Plus, CM™-INTANK (A) outputs measurement value data. It is possible to set designated value ranges with the DC4 to 20mA, or set the output range.

### RS-232C output

The PRM series and the CM™ series (excludes certain models) are equipped with an RS-232C data output feature for computer use.

## Detection Section and Calculation Display Section

PRM™ series

The PRM™ series is divided into 2 parts: 1. the "detection section" that is incorporated into the piping system or connected directly to the tank, and 2. the "calculation display" section which is affixed to devices such as the control box. The detection section and the calculation section are connected with one cable that can be extended to a maximum length of up to 200m (a 15m cable is included as a standard accessory). Refractive index and temperature data from the detection section is sent to the calculation display section via the RS-485's digital signal. The calculation display section supplies power to the detection section.



## Alarm

PRM™ series

The PRM™ series is equipped with a function that outputs a signal for an alarm when measurement values that exceed the pre-set ranges are detected. Out of spec sample (product) of a factory's manufacturing line is instantly discovered, making this a supremely useful and convenient feature. Alarm output can be configured for maximum and minimum values of management ranges for products that are up to standards in a manufacturing process that has incorporated an in-line refractometer, or for when a few seconds of unacceptable measurement values are continuously measured. Using a relay driver, it is possible to detect and regulate the occurrence of abnormal values through measures such as turning on the alarm LED light, or sending input to a sequencer.



## User-scales

PRM™ series

Aside from Brix and refractive index, the PRM™ series has customizable user-scales for displaying the specific concentration of a sample. By using the liquid sample's "refractive index vs. concentration (at every temperature)" data and transmitting it via RS-232C as a .txt file, user-scale data can be saved.

\*Direct concentration is displayed without the need to convert from refractive index or Brix.

Programmable concentration setting

File	Edit	Search	Help				
*T	5	5.0	10.0	20.0	30.0	40.0	50.0
*N	2	0.00	10.00	20.00	30.00	40.00	50.00
*C	1	1.33390	1.38050	1.38500	1.40840	1.42370	1.43590
*C	2	1.33389	1.38010	1.38440	1.40570	1.42280	1.43480
*C	3	1.33299	1.35910	1.38310	1.40410	1.42090	1.43260
*C	4	1.33194	1.35780	1.38160	1.40240	1.41900	1.43060
*C	5	1.33061	1.35640	1.38010	1.40070	1.41710	1.42840
*C	6	0.0	0.0	0.0	0.0	0.0	0.0

There is a risk for the measuring instrument of a production line that the sample (liquid) which flows through the pipes may adhere to the sensor section.

Moreover, there are cases where it is more difficult to clean off build-up on measuring instruments that have been inserted in the main production line than on instruments not installed in the main line. The following sections will explain build-up prevention tips, solutions, and strategies for ATAGO's in-line refractometers.

### A Completely Flat Sample Stage

The wetted section (the prism surface and prism stage) which contacts the sample inside the sample stage of the PRM™ series and CM™-800α has been completely and entirely flattened.

To eliminate even the slightest of gaps between the prism surface and prism stage, during manufacturing, the sample stage is repolished down to one-hundredth of a millimeter (0.01 mm). By making the sample stage completely flat, sample build-up on the prism surface is kept at a minimum.



### Ultrasonic Cleaner for Build-Up Prevention (optional accessory)

Depending on the properties of the sample, there are cases where build-up on the prism surface is utterly unavoidable.

For these types of cases, the ultrasonic cleaner, US-α™ is available. The US-α™ is a device that attaches directly facing the detection section of an installed process refractometer, and through the vibrations of its ultrasonic waves, prevents and reduces build-up on the in-line refractometer's prism surface.

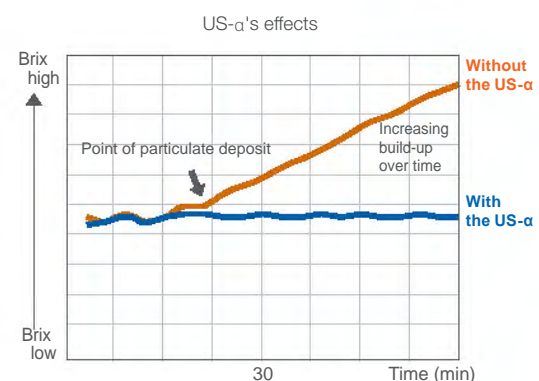

\* Even now, repeated experiments and inspections are being conducted with a variety of samples.



### Prism Wiper (optional accessory)

The prism wiper is an optional accessory that attaches directly facing the detection section of an in-line refractometer installed in the piping system for manually wiping build-up off the prism surface. When necessary, the wiper can be manually operated and the prism wiper's rubber tip wipes build-up off of the prism surface. There is no need to stop the production line and remove the in-line refractometer every time in order to clean the prism surface. Recommended for cutting oil and other highly viscous samples.



### Ultra-Easy Prism Wiper (optional accessory)

To prevent in-line densitometers from getting stuck, we have introduced an easy-to-use wiper that is cheaper and easier to clean. By removing the top handle, you can use a cotton swab to directly wipe off any deposits on the prism surface.



### Improved Sample Inlet

The former π type pipe has been discontinued. The current straight type and L type sample inlet fittings have been improved. With an improved design, there is no sample buildup, allowing for improved flow as well as enhanced temperature detection.

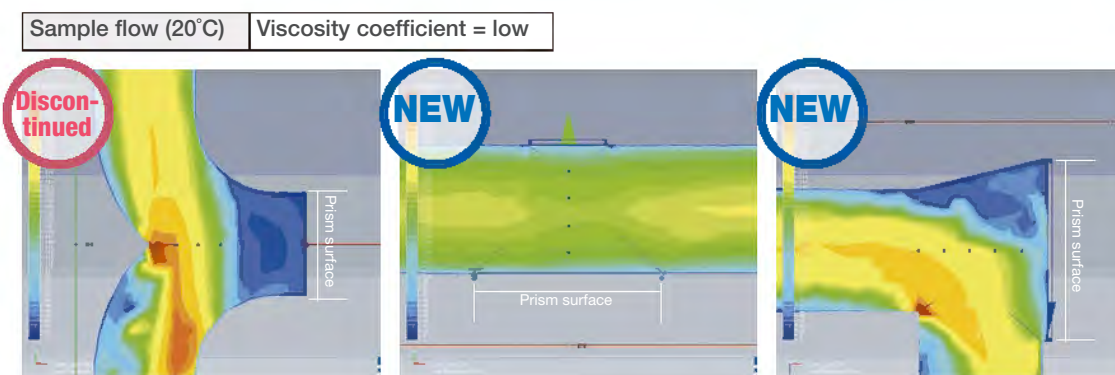

The flow velocity of the sample around the prism is slow. It is possible to increase and stably measure the flow velocity around the prism.

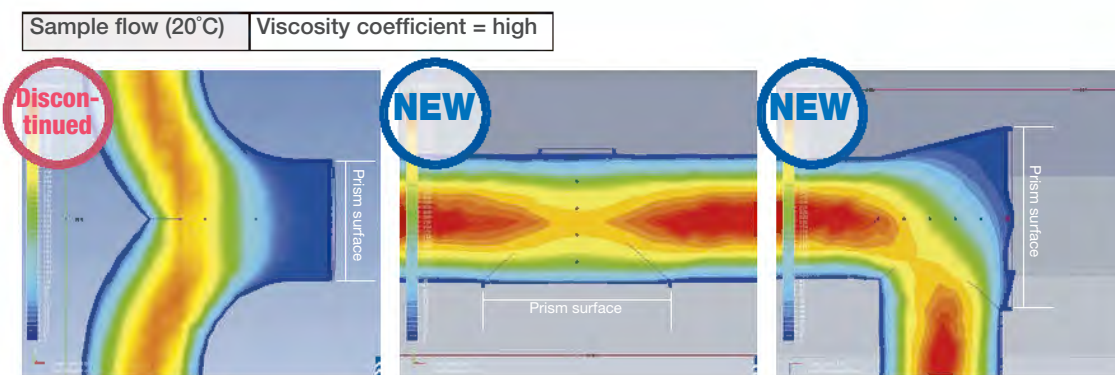

When the viscosity is high, the flow velocity near the wall's surface will drop, making it difficult for the sample to flow around the prism. Although high viscosity is causing the flow velocity of the wall's surface to drop, sample is flowing freely around the prism without stagnation. The enhancements from the former π type pipe can be readily seen in how the flow velocity around the prism is maintained.

## Build-Up Prevention — Introducing tips, solutions, and proven strategies accumulated over many years of experience to prevent build-up.

ATAGO has examples of proven strategies to prevent years of build-up from accumulating. As an example of our many records of proven strategies, we will introduce feedback from some of our customers who have installed the ultrasonic cleaner, US- $\alpha$ <sup>TM</sup>.

### Sugar Refinery

#### Sugar Syrup



This customer experienced operational errors from the accumulation of lime calcium (used to remove impurities of raw sugar) deposits on the sensor section of their process refractometer. Therefore, they installed **the ultrasonic cleaner, US- $\alpha$ <sup>TM</sup>**. The customer confirmed that there was absolutely no build-up once the pipeline was cleaned, and after 20 days had passed it was still in pristine condition. Occasionally, the customer performs some maintenance such as cleaning with hot water and gently wiping it off just in case, but even now, they are not experiencing any issues with measurement values. They had a refractometer made by another manufacturer which they periodically removed from the pipeline and performed cleaning. By purchasing an ATAGO in-line refractometer along with the US- $\alpha$ <sup>TM</sup>, cleanings were reduced, making the process easy and hassle-free.

### Auto Parts Company

#### Surface Treatment Agents



This customer experienced a phenomenon in which their measurement values increased due to surface treatment agents adhering to the sensor section of their process refractometer. The process refractometer was attached to a pipe that was in a high, hard to reach location, but removal was necessary to perform cleaning every single time there was build-up. By using  $\alpha$ <sup>TM</sup>, build-up no longer occurs and since there is no need to perform cleaning, work efficiency increased.

### Paper Manufacturing Company

#### Gelling Agent (Coating)



The purpose of a gelling agent is to stabilize the finished coating by applying it on the paper. This customer confirmed that throughout 32 continuous hours of operating the manufacturing line, gelling agent build-up on the sensor section would occur every 5 to 7 hours. Due to the gelling agent's properties, build-up was prone to occur, and the customer fretted over whether or not management with a refractometer was really appropriate for their application. It was at that time the customer found out about  $\alpha$ <sup>TM</sup>, and demoed it. Once manufacturing begins, the process cannot be stopped, so the implementation of the US- $\alpha$ <sup>TM</sup> has been tremendously helpful in eliminating the occurrence of build-up.

### Food Company (e.g. Powdered Milk)

#### Powdered Milk



The production line is operated for about 10 days in a month and produces 38 tons of powdered milk at one time. The concentrate's concentration is measured with a process refractometer, but it must be removed and wiped clean every 6 to 7 hours for the CIP process when severe build-up occurs, and once a month for routine cleaning. Alkali used in the CIP process eliminates acids, but calcium and magnesium remain. Through the implementation of **the ultrasonic cleaner, US- $\alpha$ <sup>TM</sup>**, even if cleaning is not done frequently, measurement values are correctly displayed, and the customer is fully utilizing the convenience and usefulness of the US- $\alpha$ .

### Chemical Company

#### DMF (Dimethylformamide)



DMF is a solvent used in acrylic fiber synthesis. Up to now, concentration control required that the unit be cleaned once every 30 minutes, but in tests using our **the ultrasonic cleaner, US- $\alpha$ <sup>TM</sup>**, the instrument was able to measuredly stably for 10 consecutive hours without cleaning, improving factory efficiency.

## In-line Refractometer Terminology

### ■ What is VARIVENT®?

The VARIVENT® valves contribute to hygienic and fully cleanable process systems.

The wetted parts of In-line Refractometers may be customized to work with VARIVENT® components.

PRM<sup>TM</sup> series and CM<sup>TM</sup> series fittings that meet VARIVENT standards are also available.

\* VARIVENT® is a registered trademark of GEA Tuchenhausen.

### ■ What is PROFIBUS?

PROFIBUS is a communication protocol for fieldbus, industrial computer network between the field device and its controller in factory automation applications. PROFIBUS is standardized under such standards as IEC 61158/61784 and EN50170. The PRM<sup>TM</sup> and CM<sup>TM</sup> In-line Refractometers may become PROFIBUS-compatible by the use of an adapter connected to the RS-232C port.

### ■ Sample Stage Material: What is SUS316/SUS304?

SUS316 is a type of enhanced stainless steel that contains chromium (Cr) and nickel (Ni). Molybdenum (Mo) is added, giving it superior corrosion and pitting resistance than SUS304\*1. It has excellent corrosion resistance to a variety of materials, from seawater to all kinds of other mediums.

\*SUS304 is a stainless steel made up of 18% chromium (Cr) and 8% nickel (Ni).

### ■ Sample Stage Material: What is SUS316L?

SUS316L is a material with a carbon (C) amount below 0.03%, in contrast to SUS316, which has a carbon amount below 0.08%. Further differences are the amount of Ni contained in SUS316 is 10 to 14%, whereas SUS316L contains 12 to 15%. Therefore, SUS316L is favored over SUS316 for its corrosion resistance that contains superb work hardening (cold forming) and intergranular corrosion resistant properties.

### ■ What is COP (Clean Out of Place)?

COP is a method of cleaning wherein the machinery installed in the production equipment are removed, disassembled and cleaned. It is used for cleaning machinery and parts with complex structures and components. Machinery that is simple to disassemble and reassemble, and easily cleaned is highly demanded in regards to cleanliness.

### ■ What is CIP (Clean in Place)?

CIP is a system wherein the production equipment are efficiently and safely automatically cleaned without being disassembled. The machinery isn't simply washed; it's a method of cleaning that also involves the controlling and inhibiting microorganisms.

### ■ What is SIP (Sterilization in Place)?

SIP is a system wherein the production equipment are sterilized (bacteria are automatically eradicated) without being disassembled. Below are some examples of sterilization methods:

- Physical sterilization through heat (pasteurization)
- Filtration through a filter or membrane
- Irradiation through radiation or ultraviolet rays
- Chemical sterilization through the use of pharmaceuticals

Devices tested and confirmed compatible  
HMS Industrial Networks  
Anybus Communicator



# Product Lineup (In-line Type)

Contact ATAGO for explosion proof models.

## In-line Refractometer

## In-line Brix Monitor

**Product Structure** Separate detection section and calculation display section model

Integrated model: A unit equipped with an operating panel and display section in the front and a sensor/detection section in the back.

Separate model

Model PRM™-100 α DX

Model PRM™-2000 α DX

Model CM™-800 α

Model CM™-IS α



Cat.No. 3676

Cat.No. 3686

Cat.No. 3564

Cat.No. 3700

**Measurement items** Refractive index (nD)  
Brix  
concentration (Conc) (User scale)

Refractive index (nD)  
Brix  
concentration (Conc) (User scale)

Brix

Refractive index (nD)  
Brix  
concentration (Conc)

**Measurement range** nD : 1.32000 ~ 1.55700  
Brix : 0.00 ~ 100.00%

nD : 1.32069 to 1.36500  
Brix: 0.000 to 20.000%

0.00 ~ 80.0%

nD : 1.32000 to 1.49100  
Brix: 0.0 to 80.0%

**Measurement accuracy** nD : ±0.00010  
Brix: ±0.05%

nD : ±0.00001  
Brix: ±0.007%  
(nD : 1.32069 to 1.33681, Brix: 0.000 to 2.000%)  
nD : ±0.00010  
Brix: ±0.050%  
(nD: from 1.33682 up, Brix: from 2.001% up)







± 0.1%

nD : ±0.0002  
Brix: ±0.1%

Special scales are available for the CM™-800α series. For more details, please refer to pg. B28.

Special scales are available for the CM™-ISα series. For more details, please refer to pg. B32.

# Product Lineup (In-line Type)

	In-line Brix Monitor			Ultrasonic Cleaner(Optional)	Digital Immersion Refractometer	
<b>Product Structure</b>	Integrated model: A unit equipped with an operating panel and display section in the front and a sensor/detection section in the back.			Separate model	Integrated model: Optimized for easy installation.	
<b>Model</b>	CM™-BASE $\alpha$	CM™-BASE $\alpha$ -Plus	CM™-BASE $\alpha$ -MAX	US- $\alpha$ ™	CM™-BASE $\beta$	PAN™-1DC
						
<b>Cat.No.</b>	3713	5811	5821	(1S) : 9113-00 (2S) : 9113-01 (3S) : 9113-02	5851 (M) : 5852 (L) : 5853	3606 (M) : 3607 (L) : 3608 Customizable length : 3609
<b>Measurement items</b>	Brix	Brix	Brix		Brix	Brix
<b>Measurement range</b>	0.0 to 33.0%	0.0 to 93.0%	0.0 to 93.0%		0.0 to 93.0%	0.0 to 42.0%
<b>Measurement accuracy</b>	±0.5%	±0.5%	±0.2%		±0.2%	±0.2%

Special scales are available for the CM™-BASE $\alpha$  series. For more details, please refer to pg. B40.

# Product Lineup (Tank Type)

## Direct Tank Mounting Refractometer

<b>Product Structure</b>	Separate detection section and calculation display			Integrated model: A unit equipped with an operating panel and display section in the front and a sensor/detection section in the back.				
<b>Model</b>	PRM™-TANK100 α DX(FER)	PRM™-TANK2000 α DX(FER)	PRM™-TANK α (FLN)	CM™-TANK α (FER)	CM™-TANK α -SW(FER)	CM™-TANK α -EG(FER)	CM™-TANK α -Urea(FER)	CM™-INTANK
								
<b>Model</b>	3677	3687	3575	3567	3701	3716	3718	(A) :3617 (D) :3627
<b>Measurement items</b>	Refractive index (nD) Brix concentration (Conc) (User scale)	Refractive index (nD) Brix concentration (Conc) (User scale)	Refractive index (nD) Brix concentration (Conc) (User scale)	Brix	Salinity(W/W)	Ethylene glycol(V/V)	Urea(Adblue)	Brix
<b>Measurement range</b>	nD : 1.32000 to 1.55700 Brix: 0.00 to 100.00%	nD : 1.32069 to 1.36500 Brix: 0.000 to 20.000%	nD : 1.31700 to 1.51000 Brix : 0.00 to 85.00%	0.00 to 80.0%	0.00 to 28.0%	0.00 to 105.5%	0.0 to 55.0%	0.0 to 33.0%
<b>Measurement accuracy</b>	nD : ±0.00010 Brix : ±0.05%	nD : ±0.00001 Brix : ±0.007% (nD : 1.32069 to 1.33681, Brix : 0.000 to 2.000%) nD : ±0.00010 Brix : ±0.050% (nD : from 1.33682 up, Brix : from 2.001% up)	nD : ±0.0001 Brix : ±0.1%	±0.1%	±0.1%	±0.4%	±0.3%	±0.5%
<b>Connection Diameter</b>	3S Ferrule	3S Ferrule	JIS Flange 125A	3S Ferrule	3S Ferrule	3S Ferrule	3S Ferrule	

# PRM™-100α DX



Materials in contact with the solution  
Prism: Sapphire  
Prism stage: SUS316L  
\*The packing is made by an excellent chemical resistance material.

### User scale

User scale (concentration) can be programmed with a PC.

ファイル名	編集	書式	表示	ヘルプ
*T	5	5.0	10.0	20.0
*N	2	0.00	10.00	20.00
*C	1	1.33390	1.36050	1.38500
*C	2	1.33389	1.36010	1.38440
*C	3	1.33299	1.35910	1.38310
*C	4	1.33194	1.35790	1.38160

### Alarm function

Equipped with an alarm output function that transmits a signal when pre-set high- and low-limit values are exceeded.



With a measurement range of 0.00 to 100.00% Brix, the refractive index, Brix, concentration, water content and contamination ratio can be continuously measured for various solutions.

### Specifications

Ca.No.	3676
Measurement items	Refractive index (nD), Brix (temperature compensation according to sucrose), concentration (Conc) (User scale), and temperature (°C)
Measurement range	Refractive index (nD) : 1.32000 to 1.55700, Brix : 0.00 to 100.00%, Temperature: -5.0 to 160.0°C
Resolution	① Refractive index (nD): 0.0001 Brix : 0.1% ② Refractive index (nD) : 0.00001 Brix: 0.01%(Factory default setting) * by selection
Measurement accuracy	Refractive index (nD) : ±0.00010 Brix: ±0.05% * When measuring standard solutions (sucrose) under stable temperature conditions.
Temperature compensation range	5.0 to 100.0°C
Alarm output	Open-collector output for high- and low-limit settings (alarm output).
Measurement Interval	Approximately 1 measurement/second. *Same for output intervals.
Pressure resistance	0.98MPa (detection section)
Ambient temperature	5 to 40°C
Power consumption	30VA

### Output method

**RS-232C output**

**Recorder output (DC4-20mA)**

Calculation display section			D—Sub connector (PC side)		
Pin No.	Cord color	Signal name	Pin No.	Cord color	Signal name
1	Red ●	RXD	2	Red & White ●○	RXD
2	Red & White ●○	TXD	3	Red ●	TXD
3	Black ●	GND	5	Black ●	GND
			7	—	RTS
			8	—	CTS

Pin No.	Cord color	Signal name	Output
1	Red ●	Refractive Index (Brix, concentration) +	4 to 20mA
2	Black ●	Temperature +	4 to 20mA (-5 to 160°C)
3	Red & White ●○	Refractive Index (Brix, concentration) -	4 to 20mA
4	Black & White ●○	Temperature -	4 to 20mA (-5 to 160°C)

### Dimensions (unit of length: mm)

Detection section : 10.8×17.26×10.8cm, 2.6kg

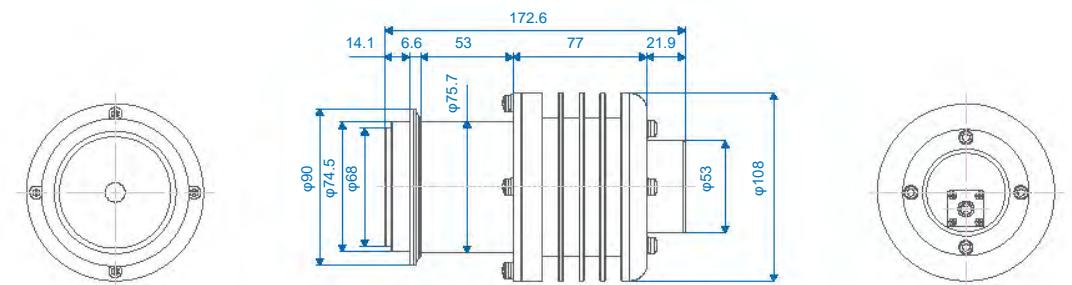

Power supply :AC100 to 240V, 50/60 Hz  
Cable:Detection section - Calculation display section (power supply 12V and RS-485) Length: standard 15m (maximum up to 200m)

Calculation display section : 19.2×10×24cm, 3.3kg

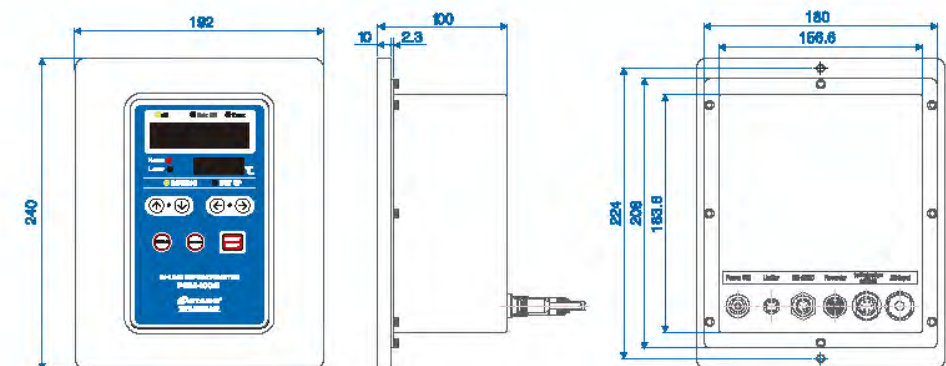

# PRM™-2000α DX



Materials in contact with the solution  
Prism: Sapphire  
Prism stage: SUS316L  
\*The packing is made by an excellent chemical resistance material.

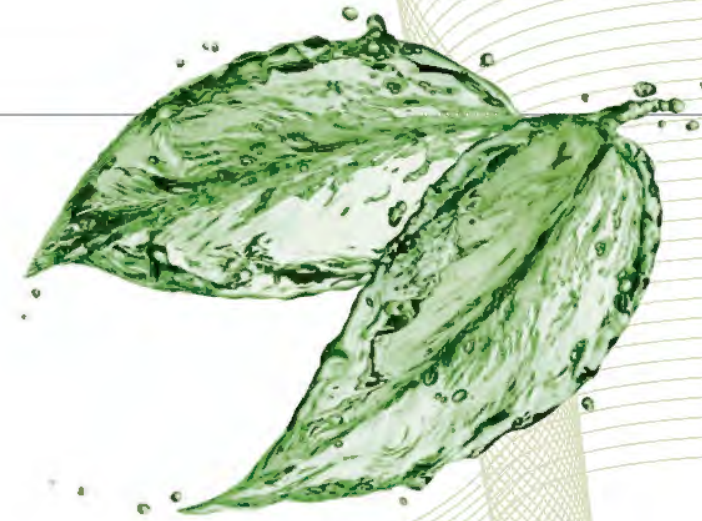

### User scale

User scale (concentration) can be programmed with a PC.

### Alarm function

Equipped with an alarm output function that transmits a signal when pre-set high- and low-limit values are exceeded.

ファイル名	編集	書式	表示	ヘルプ
*T	5	5.0	10.0	20.0
*N	2	0.00	10.00	20.00
*C	1	1.33390	1.36050	1.38500
*C	2	1.33369	1.36010	1.38440
*C	3	1.33288	1.35910	1.38310
*C	4	1.33194	1.35760	1.38160



A compact model that has the display and operation panel in the front and the detection section on the back.  
It measures 0.000 to 20.000% Brix at a ±0.050% accuracy.

### Specifications

Ca.No.	3686		
Measurement items	Refractive index (nD), Brix (Temperature compensation corresponding to 3 types of samples: sucrose, high-fructose corn syrup, and sugar-free beverages [2% or less]), concentration (Conc) (User scale), and temperature (°C).		
Measurement range	Refractive index (nD): 1.32069 to 1.36500, Brix: 0.000 to 20.000%, Temperature: -35.0 to 165.0°C		
Resolution	① Refractive index (nD): 0.00001 Brix: 0.001% (Factory default setting) ② Refractive index (nD): 0.00001 Brix: 0.005% ③ Refractive index (nD): 0.00001 Brix: 0.01% * by selection		
Measurement accuracy	Refractive index (nD): ±0.00001 Brix: ±0.007% (Refractive index (nD): 1.32069 to 1.33681, Brix: 0.000 to 2.000%) Refractive index (nD): ±0.00010 Brix: ±0.050% (Refractive index (nD): from 1.33682 up, Brix: from 2.001% up) * Accuracy may vary when measuring samples above or below Brix 2% due to temperature compensation and high accuracy specifications.		
Temperature compensation range	5 to 90°C		
Alarm output	Open-collector output for high- and low-limit settings (alarm output).		
Measurement interval	Approximately 1 measurement /second (factory default), 5 interval options. *Same for output intervals.		
Pressure resistance	0.98MPa (detection section)		
Ambient temperature	5 to 40°C		
Power consumption	30VA		

### Output method

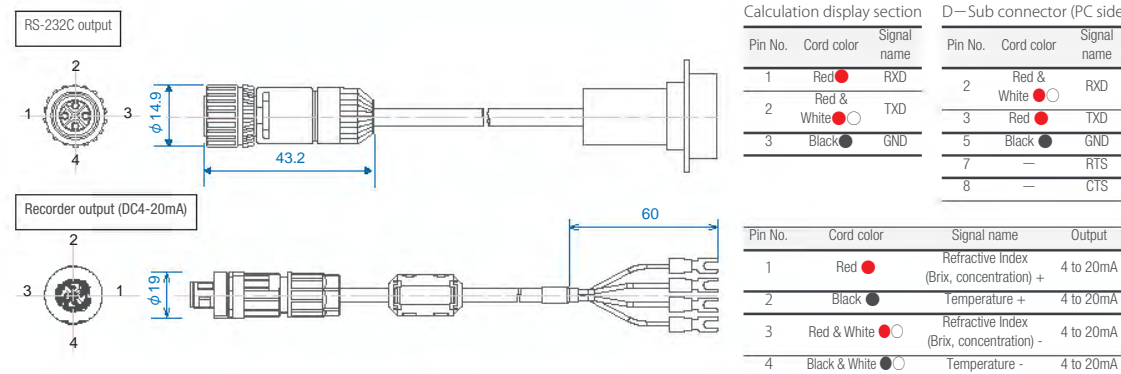

### Dimensions (unit of length: mm)

Detection section : 10.8×25.52×10.8cm, 3.2kg

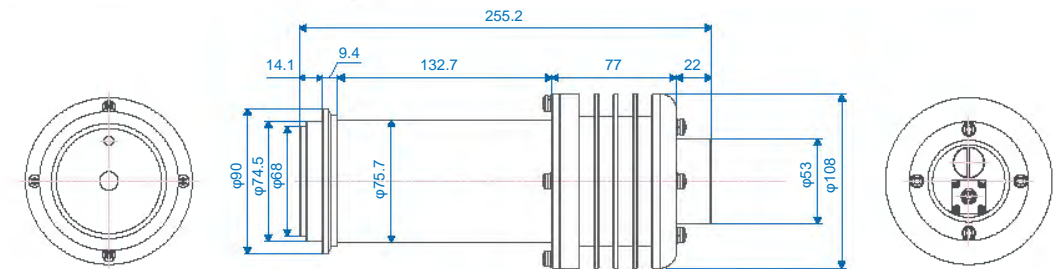

Power supply :AC100 to 240V, 50/60 Hz  
Cable:Detection section - Calculation display section (power supply 12V and RS-485) Length: standard 15m (maximum up to 200m)

Calculation display section : 19.2×10×24cm, 3.3kg

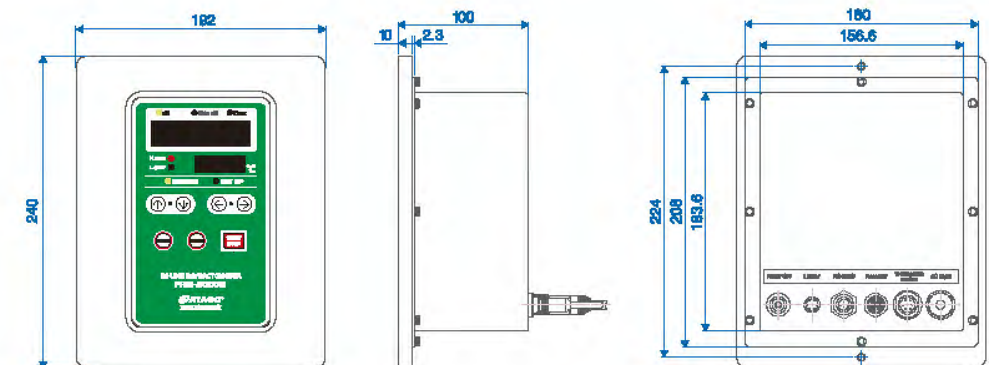

# CM™-800α



Materials in contact with the solution  
Prism: Sapphire  
Prism stage: SUS316L

\*The packing is made by an excellent chemical resistance material.



A compact model that has the display and operation panel in the front and the detection section on the back.  
It measures 0.00 to 80.0% Brix at a  $\pm 0.1\%$  accuracy.

## Specifications

Cat.No.	3564
Measurement items	Brix (ATC according to the sample liquid), Temperature ( $^{\circ}\text{C}$ / $^{\circ}\text{F}$ )
Measurement range	Brix: 0.00 to 80.0%, Temperature: $-15$ to $160^{\circ}\text{C}$ / $5$ to $320^{\circ}\text{F}$
Resolution	Brix: 0.01 or 0.1% (With an option to display measurements between 0.00 and 9.99% to the 2nd decimal place.), Temperature: $1^{\circ}\text{C}$ / $1^{\circ}\text{F}$
Measurement accuracy	Brix: $\pm 0.1\%$ , Temperature: $\pm 1^{\circ}\text{C}$ / $\pm 1^{\circ}\text{F}$
Temperature compensation range	$5$ to $100^{\circ}\text{C}$
Measurement Interval	Approximately 1 measurement /second (factory default), 5 interval options. *Same for output intervals.
Pressure resistance	$0.98\text{MPa}$
Ambient temperature	$5$ to $40^{\circ}\text{C}$
Power consumption	Power consumption when using DC24V: 3VA; when using AC100-240V: 15VA.

## Output method

Power supply :DC24V \* An optional accessory, "AC Adapter AD-32" is available to convert AC100V to DC24V.  
(Reflective index output is standard with RS-232C; it is optional with recorder.)

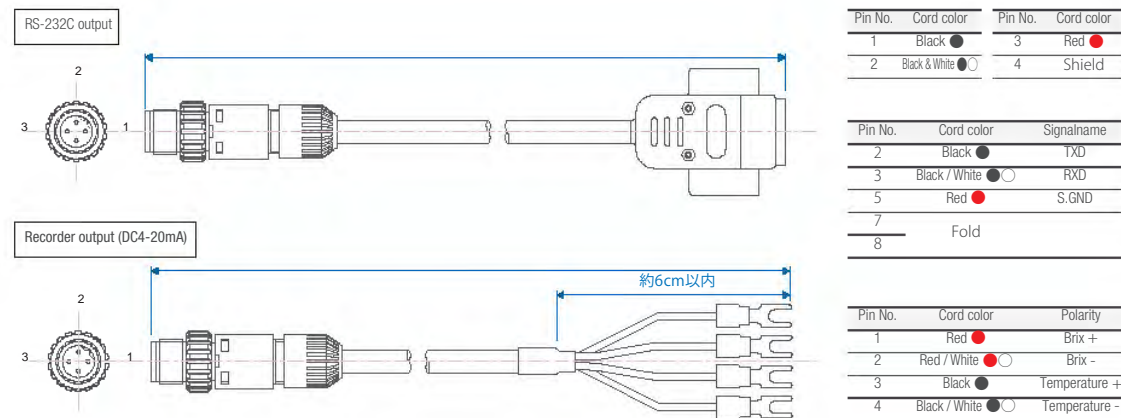

## Dimensions (unit of length: mm)

16×16.7×11cm, 2.4kg (Main Unit only)

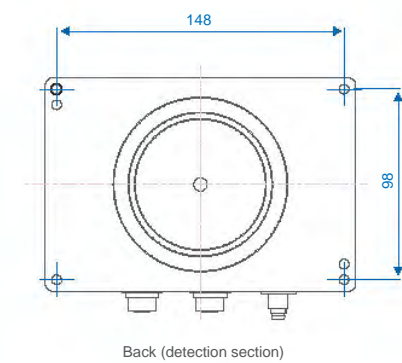
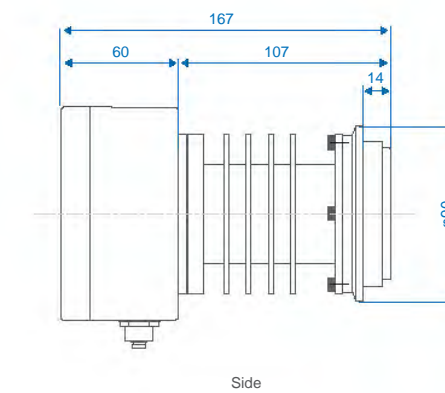
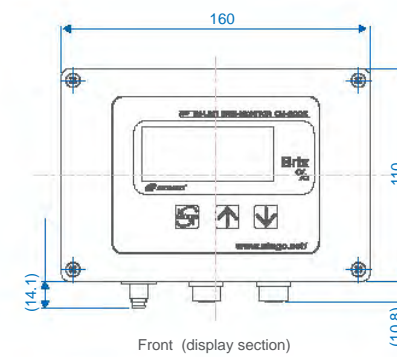

# CM™-800α series



## <Special Scales>



Materials in contact with the solution  
Prism: Sapphire  
Prism stage: SUS316L

\*The packing is made by an excellent chemical resistance material.

### Ethylene Glycol Concentration

#### CM™-800α-EG

##### Specifications

Cat.No.	3531
Measurement items	⊕ Ethylene glycol concentration(%: v/v) (ATC), ⊕ Ethylene glycol freezing point (ATC), ⊕ Temperature(°C / °F)
Measurement range	⊕ 0.0 to 90.0%, ⊕ -50 to 0°C / -58 to 32°F
Resolution	⊕ 0.1%, ⊕ 1°C / 1°F
Measurement accuracy	⊕ ±0.4%, ⊕ ±1°C / ±1°F

### Saline Concentration

#### CM™-800α-SW

##### Specifications

Cat.No.	3533
Measurement items	⊕ Salinity(%: W/W) (ATC), ⊕ Temperature(°C / °F)
Measurement range	⊕ 0.00 to 28.0%, ⊕ -15 to 160°C / 5 to 320°F
Resolution	⊕ 0.01 or 0.1(2nd decimal place shown per selection for 0.00 - 9.99%) ⊕ 1°C / 1°F
Measurement accuracy	⊕ ±0.1%, ⊕ ±1°C / ±1°F

### Hydrogen Peroxide Solution Concentration

#### CM™-800α-H<sub>2</sub>O<sub>2</sub>

##### Specifications

Cat.No.	3522
Measurement items	⊕ H <sub>2</sub> O <sub>2</sub> (%: W/W) (Temperature Compensation Range: 10 to 35°C) ⊕ Temperature(°C / °F)
Measurement range	⊕ 0.0 to 50.0%, ⊕ -15 to 160°C / 5 to 320°F
Resolution	⊕ 0.2%, ⊕ 1°C / 1°F
Measurement accuracy	⊕ ±0.6%, ⊕ ±1°C / ±1°F

ATC=Automatic Temperature Compensation

### Propylene Glycol Concentration

#### CM™-800α-PG

##### Specifications

Cat.No.	3532
Measurement items	⊕ Propylene glycol concentration(%: v/v) (ATC), ⊕ Propylene glycol freezing point (ATC), ⊕ Temperature(°C / °F)
Measurement range	⊕ 0.0 to 90.0%, ⊕ 0 to -50°C / 32 to -58°F
Resolution	⊕ 0.1%, ⊕ 1°C / 1°F
Measurement accuracy	⊕ ±0.4%, ⊕ ±1°C / ±1°F

### Sodium Hydroxide Concentration

#### CM™-800α-NaOH

##### Specifications

Cat.No.	3521
Measurement items	⊕ NaOH(%: W/W) (Temperature Compensation Range: 10 to 35) ⊕ Temperature(°C / °F)
Measurement range	⊕ 0.0 to 38.0%, ⊕ -15 to 160°C / 5 to 320°F
Resolution	⊕ 0.1%, ⊕ 1°C / 1°F
Measurement accuracy	⊕ ±0.2%, ⊕ ±1°C / ±1°F

### Ethyl Alcohol Concentration

#### CM™-800α-Ethanol(V/V)

##### Specifications

Cat.No.	3523
Measurement items	⊕ Ethanol(%:V/V) (Temperature Compensation Range: 5 to 30°C) ⊕ Temperature(°C / °F)
Measurement range	⊕ 0.0 to 53.0%, ⊕ -15 to 160°C / 5 to 320°F
Resolution	⊕ 0.1%, ⊕ 1°C / 1°F
Measurement accuracy	⊕ ±1.0%, ⊕ ±1°C / ±1°F

\*Not explosion proof. Contact ATAGO regarding explosion proof.

### Isopropyl Alcohol Concentration

#### CM™-800α-IPA

##### Specifications

Cat.No.	3524
Measurement items	⊕ IPA (Temperature Compensation Range: 10 to 35 °C) ⊕ Temperature(°C / °F)
Measurement range	⊕ 0.0 to 50.0%, ⊕ -15 to 160°C / 5 to 320°F
Resolution	⊕ 0.1%, ⊕ 1°C / 1°F
Measurement accuracy	⊕ ±0.4%, ⊕ ±1°C / ±1°F

\*Not explosion proof. Contact ATAGO regarding explosion proof.

### N-Methyl-2-Pyrrolidone Concentration

#### CM™-800α-NMP

##### Specifications

Cat.No.	3526
Measurement items	⊕ NMP (Temperature Compensation Range: 10 to 60) ⊕ Temperature(°C / °F)
Measurement range	⊕ 0.0 to 100.0%, ⊕ -15 to 160°C / 5 to 320°F
Resolution	⊕ 0.01 to 9.99% (2nd decimal place shown per selection for 0.00 - 9.99%) ⊕ 1°C / 1°F
Measurement accuracy	⊕ ±0.1%, ⊕ ±1°C / ±1°F

\*Not explosion proof. Contact ATAGO regarding explosion proof.

### Urea Concentration

#### CM™-800α-Urea

##### Specifications

Cat.No.	3535
Measurement items	⊕ Urea(Adblue) (Temperature Compensation Range: 10 to 40) ⊕ Temperature(°C / °F)
Measurement range	⊕ 0.0 to 55.0%, ⊕ -15 to 160°C / 5~320°F
Resolution	⊕ 0.1%, ⊕ 1°C / 1°F
Measurement accuracy	⊕ ±0.3%, ⊕ ±1°C / ±1°F

### Wine Concentration

#### CM™-800α-Wine(Baume)

##### Specifications

Cat.No.	3517
Measurement items	⊕ Baume (Temperature Compensation Range: 10 to 40) ⊕ Temperature(°C / °F)
Measurement range	⊕ 0.0 to 21.0°, ⊕ -15 to 160°C / 5~320°F
Resolution	⊕ 0.1°, ⊕ 1°C / 1°F
Measurement accuracy	⊕ ±0.2°, ⊕ ±1°C / ±1°F

### Wine Concentration

#### CM™-800α-Wine(TA)

##### Specifications

Cat.No.	3519
Measurement items	⊕ T.A.1990 (Temperature Compensation Range: 10 to 40) ⊕ Temperature(°C / °F)
Measurement range	⊕ 0.0 to 26.0%, ⊕ -15 to 160°C / 5~320°F
Resolution	⊕ 0.1%, ⊕ 1°C / 1°F
Measurement accuracy	⊕ ±0.2%, ⊕ ±1°C / ±1°F

### Calcium Chloride Concentration

#### CM™-800α-CaCl<sub>2</sub>

##### Specifications

Cat.No.	3538
Measurement items	⊕ Calcium Chloride(W/W) ⊕ Temperature(°C / °F)
Measurement range	⊕ 0.0 to 35.0%, ⊕ -15 to 160°C / 5~320°F
Resolution	⊕ 0.1%, ⊕ 1°C / 1°F
Measurement accuracy	⊕ ±0.2%, ⊕ ±1°C / ±1°F

### Ethyl Alcohol Concentration

#### CM™-800α-Ethanol(W/W)

##### Specifications

Cat.No.	3525
Measurement items	⊕ Ethanol(%:W/W) (Temperature Compensation Range: 5 to 35°C) ⊕ Temperature(°C / °F)
Measurement range	⊕ 0.0 to 60.0% *Guaranteed accuracy range up to 45.0%, ⊕ -15 to 160°C / 5 to 320°F
Resolution	⊕ 0.1%, ⊕ 1°C / 1°F
Measurement accuracy	⊕ ±1.0%, ⊕ ±1°C / ±1°F

\*Not explosion proof. Contact ATAGO regarding explosion proof.

### Dimethylformamide Concentration

#### CM™-800α-DMF

##### Specifications

Cat.No.	3534
Measurement items	⊕ DMF (Automatic Temperature Compensation in accordance with the sample) ⊕ Temperature(°C / °F)
Measurement range	⊕ 0.0 to 40.0%, ⊕ -15 to 160°C / 5 to 320°F
Resolution	⊕ 0.1%, ⊕ 1°C / 1°F
Measurement accuracy	⊕ ±0.3%, ⊕ ±1°C / ±1°F

### Wort Concentration

#### CM™-800α-Plato

##### Specifications

Cat.No.	3536
Measurement items	⊕ Plato(%:W/W) (Temperature Compensation Range: 10 to 75) ⊕ Temperature(°C / °F)
Measurement range	⊕ 0.0 to 30.0%, ⊕ -15 to 160°C / 5 to 320°F
Resolution	⊕ 0.1%, ⊕ 1°C / 1°F
Measurement accuracy	⊕ ±0.2%, ⊕ ±1°C / ±1°F

### Wine Concentration

#### CM™-800α-Wine(Oe/GER)

##### Specifications

Cat.No.	3518
Measurement items	⊕ Oe(GER) (Temperature Compensation Range: 10 to 40) ⊕ Temperature(°C / °F)
Measurement range	⊕ 0 to 240°, ⊕ -15 to 160°C / 5 to 320°F
Resolution	⊕ 1°, ⊕ 1°C / 1°F
Measurement accuracy	⊕ ±1°, ⊕ ±1°C / ±1°F

### Soymilk Concentration

#### CM™-800α-Soymilk

##### Specifications

Cat.No.	3514
Measurement items	⊕ Soy Milk concentration ⊕ Temperature(°C / °F)
Measurement range	⊕ 0.0 to 20.0%, ⊕ -15 to 160°C / 5~320°F
Resolution	⊕ 0.1%, ⊕ 1°C / 1°F
Measurement accuracy	⊕ ±0.2%, ⊕ ±1°C / ±1°F

## Zener Barrier (Standard Accessories)



Materials in contact with the solution  
Prism: Sapphire  
Prism stage: SUS316L

\*The packing is made by an excellent chemical resistance material.

Intrinsically safe model based on CM™-800α, the most popular in-line product.  
It is a double scale of Brix (concentration) and refractive index.

### Specifications

Cat.No.	3700
Measurement items	Refractive index (nD), Brix (ATC according to the sample liquid), Temperature (°C / °F)
Measurement range	Refractive index (nD) : 1.32000 to 1.49100, Brix: 0.00 to 80.0%, Temperature: -15 to 160°C / 5 to 320°F
Resolution	Refractive index (nD): 0.00001 Brix: 0.01 or 0.1% (With an option to display measurements between 0.00 and 9.99% to the 2nd decimal place.), Temperature: 1°C / 1°F
Measurement accuracy	Refractive index (nD): ±0.0002 Brix: ±0.1%, Temperature: ±1°C / ±1°F
Temperature compensation range	5 to 100°C
Measurement Interval	Approximately 1 measurement /second (factory default), 5 interval options. *Same for output intervals.
Pressure resistance	0.98MPa
Ambient temperature	5 to 40°C

### Output method

Power supply : AC100 to 240V, 50/60Hz

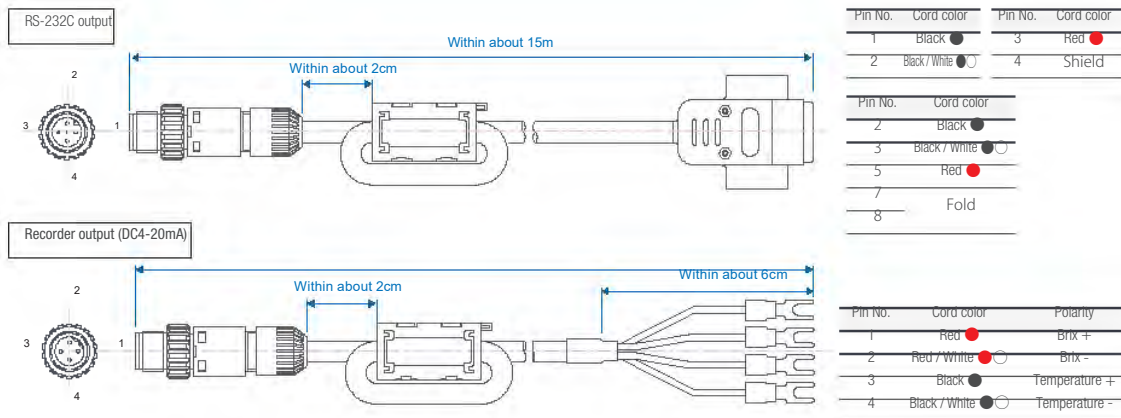

## Zener Barrier Connection Example

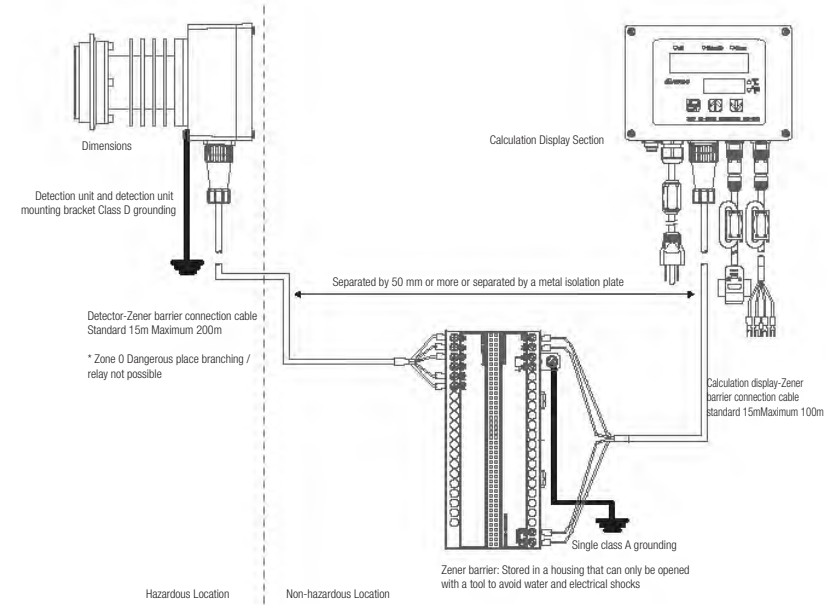

## Dimensions (unit of length: mm)

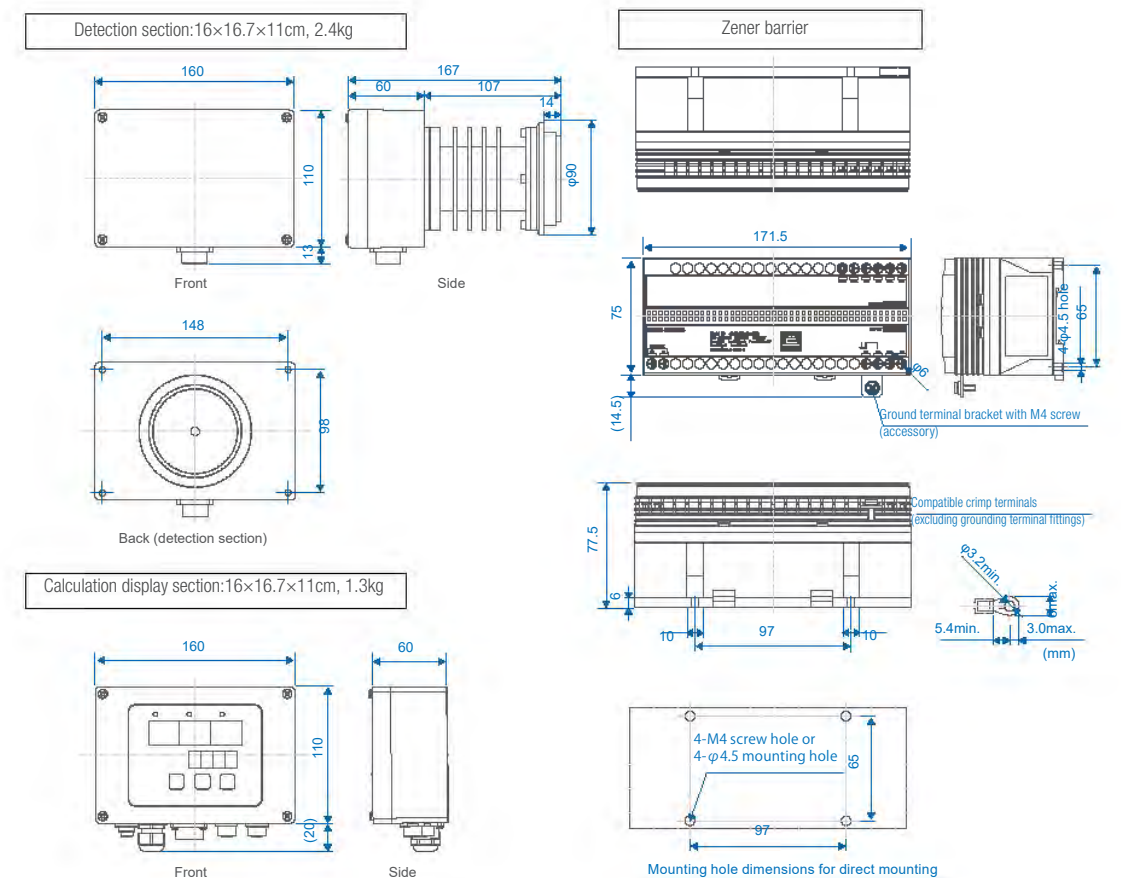

# CM™-ISα series



## <Special Scales>



Materials in contact with the solution  
Prism: Sapphire  
Prism stage: SUS316L

\*The packing is made by an excellent chemical resistance material.

### N-Methyl-2-Pyrrolidone Concentration CM™-ISα-NMP



#### Specifications

Cat.No.	5701
Measurement items	① Refractive index (nD) ② NMP Concentration (W/W) ③ Temperature(°C/°F)
Measurement range	① 1.32000 to 1.49100 ② 0.0 to 100.0% ③ -15 to 160°C / 5 to 320°F
Resolution	① 0.00001 or 0.0001 ② 0.01% or 0.1% ③ 0.1°C / 0.1°F
Measurement accuracy	① ±0.0002 ② ±0.1% ③ ±1°C / ±1°F

### Isopropyl Alcohol Concentration CM™-ISα-IPA



#### Specifications

Cat.No.	5702
Measurement items	① Refractive index (nD) ② IPA Concentration (W/W) ③ Temperature(°C/°F)
Measurement range	① 1.32000 to 1.49100 ② 0.0 to 50.0% ③ -15 to 160°C / 5 to 320°F
Resolution	① 0.00001 ② 0.1% ③ 0.1°C / 0.1°F
Measurement accuracy	① ±0.0002 ② ±0.4% ③ ±1°C / ±1°F

### Methyl Alcohol Concentration CM™-ISα-Methanol

#### Specifications

Cat.No.	5703
Measurement items	① Refractive index (nD) ② Methyl alcohol Concentration (W/W) ③ Temperature(°C/°F)
Measurement range	① 1.32000 to 1.49100 ② 0.0 to 35.0% ③ -15 to 160°C / 5 to 320°F
Resolution	① 0.00001 ② 1% ③ 0.1°C / 0.1°F
Measurement accuracy	① ±0.0002 ② ±2% ③ ±1°C / ±1°F

### Ethyl Alcohol Concentration CM™-ISα-Ethanol(V/V)

#### Specifications

Cat.No.	5704
Measurement items	① Refractive index (nD) ② Ethyl alcohol Concentration (V/V) ③ Temperature(°C/°F)
Measurement range	① 1.32000 to 1.49100 ② -2.0 to 53.5% ③ -15 to 160°C / 5 to 320°F
Resolution	① 0.00001 ② 0.1% ③ 0.1°C / 0.1°F
Measurement accuracy	① ±0.0002 ② ±1.0% ③ ±1°C / ±1°F

### Ethyl Alcohol Concentration CM™-ISα-Ethanol(W/W)

#### Specifications

Cat.No.	5705
Measurement items	① Refractive index (nD) ② Ethyl alcohol Concentration (W/W) ③ Temperature(°C/°F)
Measurement range	① 1.32000 to 1.49100 ② 0.0 to 60.0% (Quality assurance 0.0 to 45.0%) ③ -15 to 160°C / 5 to 320°F
Resolution	① 0.00001 ② 0.1% ③ 0.1°C / 0.1°F
Measurement accuracy	① ±0.0002 ② ±1.0% ③ ±1°C / ±1°F

### Dimethylformamide Concentration CM™-ISα-DMF

#### Specifications

Cat.No.	5706
Measurement items	① Refractive index (nD) ② DMF Concentration ③ Temperature(°C/°F)
Measurement range	① 1.32000 to 1.49100 ② -2.0 to 40.5% ③ -15 to 160°C / 5 to 320°F
Resolution	① 0.00001 ② 0.1% ③ 0.1°C / 0.1°F
Measurement accuracy	① ±0.0002 ② ±0.3% ③ ±1°C / ±1°F

### Ethylene Glycol Concentration CM™-ISα-EG

#### Specifications

Cat.No.	5708
Measurement items	① Refractive index (nD) ② Ethylene glycol Concentration ③ Freezing point ④ Temperature(°C/°F)
Measurement range	① 1.32000 to 1.49100 ② 0.0 to 90.0% ③ -50 to 0°C / -58 to 32°F ④ -15 to 160°C / 5 to 320°F
Resolution	① 0.00001 ② 0.1% ③ 1°C / 1°F ④ 0.1°C / 0.1°F
Measurement accuracy	① ±0.0002 ② ±0.4% ③ ±1°C / ±1°F ④ ±1°C / ±1°F

### Propylene Glycol Concentration CM™-ISα-PG

#### Specifications

Cat.No.	5709
Measurement items	① Refractive index (nD) ② Propylene Glycol Concentration ③ Freezing point ④ Temperature(°C/°F)
Measurement range	① 1.32000 to 1.49100 ② 0.0 to 90.0% ③ -50 to 0°C / -58 to 32°F ④ -15 to 160°C / 5 to 320°F
Resolution	① 0.00001 ② 0.1% ③ 1°C / 1°F ④ 0.1°C / 0.1°F
Measurement accuracy	① ±0.0002 ② ±0.4% ③ ±1°C / ±1°F ④ ±1°C / ±1°F

# CM™-BASEα



### Equipped with an offset function

Equipped with a new offset function.  
The sample can be managed at the actual concentration.

Materials in contact with the solution  
Prism: Sapphire  
Prism stage: SUS304

\*The packing is made by an excellent chemical resistance material.

Capable of data output via RS-232C + 4-20mA, CM™-BASEα has arrived.  
It can be used to manage water-soluble cutting oil, grinding fluid, cleaning fluid, etc.

### Specifications

Cat.No.	3713
Measurement items	Brix (temperature compensation according to sucrose)
Measurement range	0.0 to 33.0%
Resolution	0.1%
Measurement accuracy	±0.5%
Temperature compensation range	10 to 50°C
Measurement Interval	Approximately 2 second/per. *Same with the output intervals.
Pressure resistance	0.98MPa
Ambient temperature	5 to 40°C

Remove the unit from a pipeline if a high temperature CIP liquid will be used.

### Power Supply and Output Method

Power supply : DC24V

Connect the cable to the connector on the bottom of the CM-BASEα to supply DC24V power as well as DC4 to 20mA and RS-232C data output. The cable can be extended as an option.

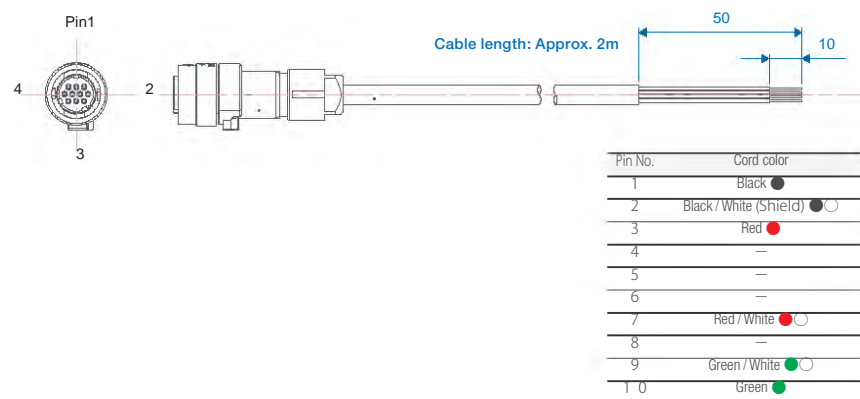

### Dimensions (unit of length: mm)

9×9×5.79cm, 820g (Main Unit only)

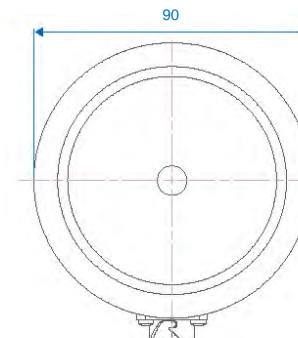

Back (detection section)

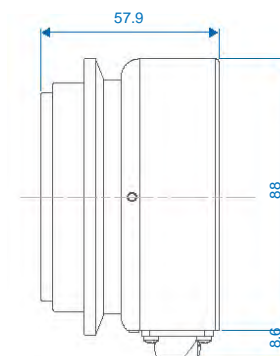

Side

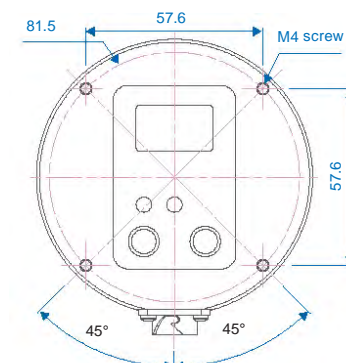

Front (display section)

# CM™-BASEα-Plus



Selected for IoT tool and recipe for small and medium-sized manufacturing industry.

## Equipped with an offset function

Equipped with a new offset function.  
The sample can be managed at the actual concentration.



Materials in contact with the solution  
Prism: Sapphire  
Prism stage: SUS304

\*The packing is made by an excellent chemical resistance material.

0.0 to 93.0% Brix measurement range.

Useful for the concentration management of water soluble cutting oil, grinding fluid, cleaning solution, and more.

## Specifications

Cat.No.	5811
Measurement items	Brix (temperature compensation according to sucrose)
Measurement range	0.0 to 93.0%
Resolution	0.1%
Measurement accuracy	±0.5%
Temperature compensation range	10 to 95°C
Measurement Interval	Approximately 2 second/per. *Same with the output intervals.
Pressure resistance	0.98MPa
Ambient temperature	5 to 40°C

Remove the unit from a pipeline if a high temperature CIP liquid will be used.

## Power Supply and Output Method

Power supply : DC24V

Connect the cable to the connector on the bottom of the CM-BASEα-Plus to supply DC24V power as well as DC4 to 20mA and RS-232C data output. The cable can be extended as an option.

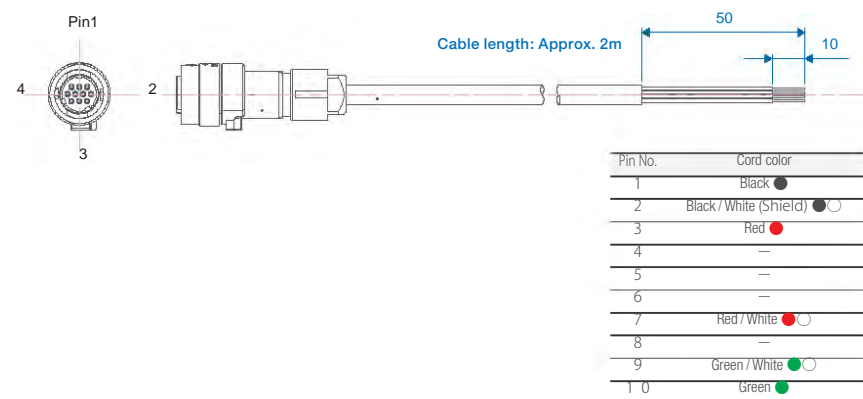

## Dimensions (unit of length: mm)

9×9×5.79cm, 830g (Main Unit only)

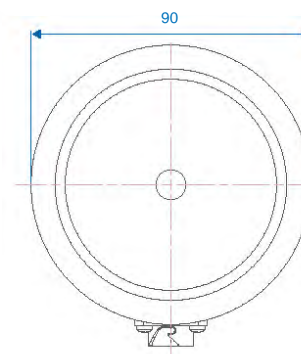

Back (detection section)

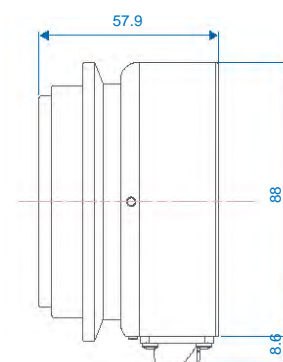

Side

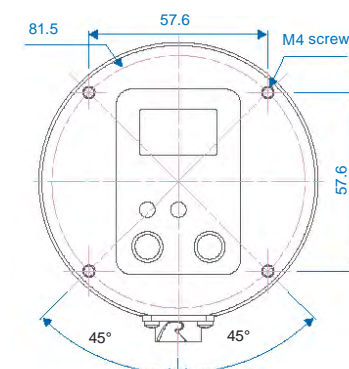

Front (display section)

# CM™-BASEα-MAX



Selected for IoT tool and recipe for small and medium-sized manufacturing industry.

## Equipped with an offset function

Equipped with a new offset function.  
The sample can be managed at the actual concentration.



Materials in contact with the solution  
Prism: Sapphire  
Prism stage: SUS304

\*The packing is made by an excellent chemical resistance material.

CM-BASEα-MAX has a measurement range of 0.0 to 93.0% Brix, and can measure at a higher accuracy of  $\pm 0.2\%$  Brix.

## Specifications

Cat.No.	5821
Measurement items	Brix (temperature compensation according to sucrose)
Measurement range	0.0 to 93.0%
Resolution	0.1%
Measurement accuracy	$\pm 0.2\%$
Temperature compensation range	10 to 95°C
Measurement Interval	Approximately 2 second/per. *Same with the output intervals.
Pressure resistance	0.98MPa
Ambient temperature	5 to 40°C

Remove the unit from a pipeline if a high temperature CIP liquid will be used.

## Power Supply and Output Method

Power supply : DC24V

Connect the cable to the connector on the bottom of the CM-BASEα-Plus to supply DC24V power as well as DC4 to 20mA and RS-232C data output. The cable can be extended as an option.

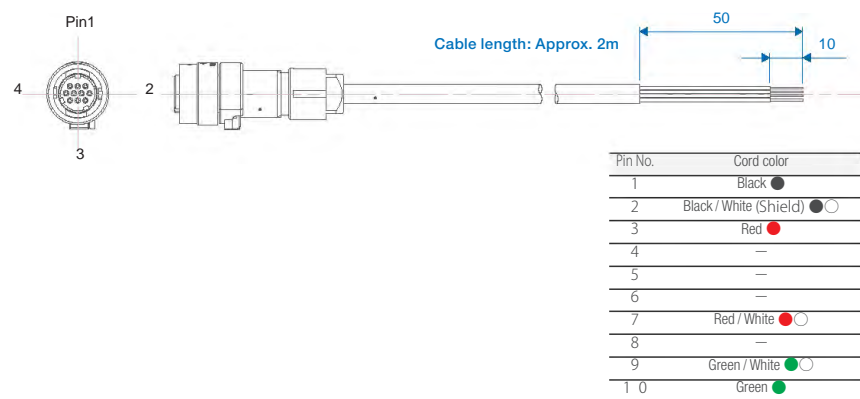

## Dimensions (unit of length: mm)

9×9×5.79cm, 830g (Main Unit only)

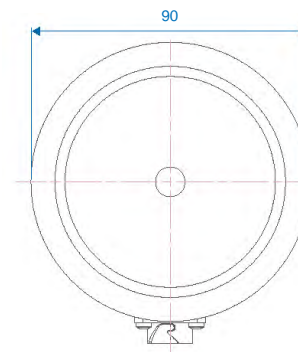

Back (detection section)

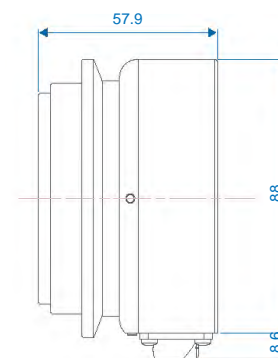

Side

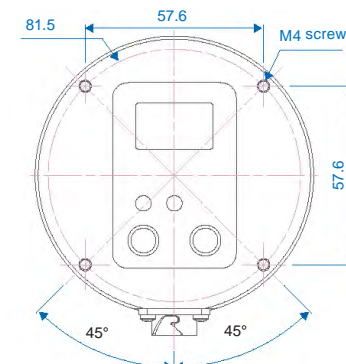

Front (display section)

# CM™ -BASEα series



## <Special Scales>



Materials in contact with the solution  
Prism: Sapphire  
Prism stage: SUS304  
\*The packing is made by an excellent chemical resistance material.

### Saline Concentration CM™ -BASEα-03S

Specifications	
Cat.No.	3783
Measurement items	Salinity(W/W) (ATC)
Measurement range	0.0 to 28.0%
Resolution	0.1%
Measurement accuracy	±0.5%

### Dimethylformamide Concentration CM™ -BASEα™ -38S

Specifications	
Cat.No.	3794
Measurement items	DMF(W/W) (ATC)
Measurement range	0.0 to 45.0%
Resolution	0.2%
Measurement accuracy	±1.0%

### Hydrogen Peroxide Solution Concentration CM™ -BASEα-39S

Specifications	
Cat.No.	3795
Measurement items	H2O2(W / W) (ATC)
Measurement range	0.0 to 50.0%
Resolution	0.2%
Measurement accuracy	±1.4%

### Sodium Hydroxide Concentration CM™ -BASEα-40S

Specifications	
Cat.No.	3796
Measurement items	NaOH(W/W) (ATC)
Measurement range	0.0 to 38.0%
Resolution	0.1%
Measurement accuracy	±0.5%

### Urea Concentration CM™ -BASEα-Urea

Specifications	
Cat.No.	3789
Measurement items	Urea(Arbue) (ATC)
Measurement range	0.0 to 50.0%
Resolution	0.1%
Measurement accuracy	±0.5%

### Sodium Chloride (S.G.) CM™ -BASEα-04S

Specifications	
Cat.No.	3784
Measurement items	Sodium chloride(S.G.) (ATC)
Measurement range	1.000 to 1.217
Resolution	0.001
Measurement accuracy	±0.005

### Sodium Chloride (Baume) CM™ -BASEα-05S

Specifications	
Cat.No.	3785
Measurement items	Sodium chloride(Baume) (ATC)
Measurement range	0.0 to 25.7°
Resolution	0.1°
Measurement accuracy	±0.5°

### Salinity Of Seawater CM™ -BASEα-06S

Specifications	
Cat.No.	3786
Measurement items	Salinity of Seawater (ATC)
Measurement range	0 to 100‰
Resolution	1‰
Measurement accuracy	±5‰

### Sea Water (S.G.) CM™ -BASEα-07S

Specifications	
Cat.No.	3787
Measurement items	Sea water(S.G.) (ATC)
Measurement range	1.000 to 1.070
Resolution	0.001
Measurement accuracy	±0.005

### Sea Water (Baume) CM™ -BASEα-08S

Specifications	
Cat.No.	3788
Measurement items	Sea water (Baume) (ATC)
Measurement range	0.0 to 10.0°
Resolution	0.1°
Measurement accuracy	±0.5°

### Concentration Of Soy milk CM™ -BASEα-27S

Specifications	
Cat.No.	3791
Measurement items	Concentration of Soy milk (ATC)
Measurement range	0.0 to 20.0%
Resolution	0.1%
Measurement accuracy	±0.5%

### Citric Acid CM™ -BASEα-29S

Specifications	
Cat.No.	3792
Measurement items	Citric acid (ATC)
Measurement range	0.0 to 10.0%
Resolution	0.1%
Measurement accuracy	±0.5%

### Acetic Acid CM™ -BASEα-30S

Specifications	
Cat.No.	3793
Measurement items	Acetic acid (ATC)
Measurement range	0.0 to 20.0%
Resolution	0.2%
Measurement accuracy	±1.0%

### Magnesium Chloride CM™ -BASEα-43S

Specifications	
Cat.No.	3797
Measurement items	Magnesium chloride (ATC)
Measurement range	0.0 to 30.0%
Resolution	0.1%
Measurement accuracy	±0.5%

### Cutting Oil CM™ -BASEα-101S

Specifications	
Cat.No.	3798
Measurement items	Cutting Oil (ATC)
Measurement range	0.00 to 50.0%
Resolution	0.1%
Measurement accuracy	±0.5%

### Dampening Waterater CM™ -BASEα-Dampening Water

Specifications	
Cat.No.	3782
Measurement items	Dampening water (ATC)
Measurement range	0.0 to 50.0%
Resolution	0.1%
Measurement accuracy	±0.5%

ATC=Automatic Temperature Compensation

# US- $\alpha$ <sup>TM</sup> (optional accessory)



\* The unit prevents sample build-up, it does not remove sample build-up after it has accumulated.

Prevents sample buildup on the prism.  
It can be installed in preexisting piping system.

### Specifications

Cat.No.	US- $\alpha$ (1S) <sup>TM</sup> : 9113-00 US- $\alpha$ (2S) <sup>TM</sup> : 9113-01 US- $\alpha$ (3S) <sup>TM</sup> : 9113-02
Power supply	AC100 to 240V, 50/60Hz
Power consumption	5VA
Cable connector	Between US- $\alpha$ 's ultrasonic device part and power supply unit: (5m)

### Connection example: US- $\alpha$ <sup>TM</sup> and PRM<sup>TM</sup>-100 $\alpha$ DX

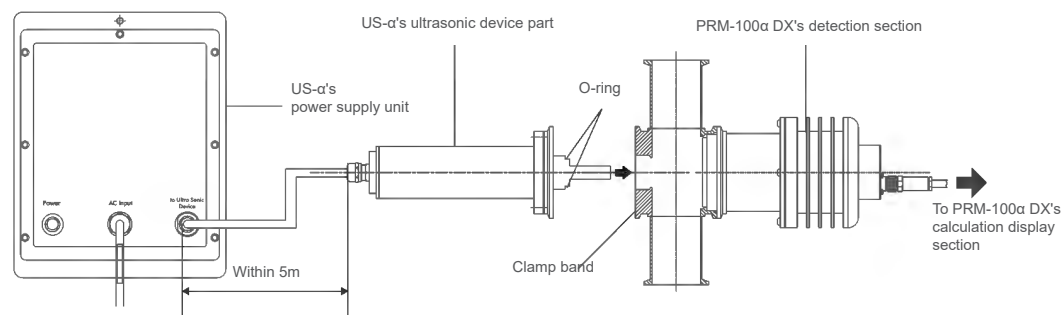

### Dimensions (unit of length: mm)

Ultrasonic cleaner attachment section: For 1S pipe: 9×9×24.93cm 2S pipe: 9×9×27.41cm 3S pipe: 9×9×29.86cm
Corresponding pipes For 1S: 1S, 1.25S, 1.5S, 20A, 25A, 32A 2S: 2S, 2.5S, 40A, 50A 3S: 3S, 65A

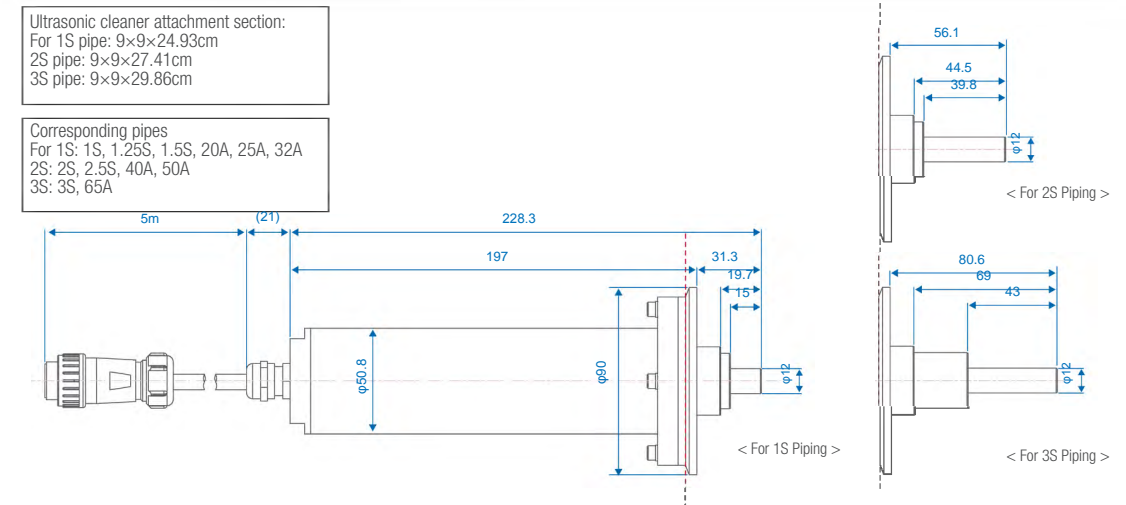

Power supply unit: 19.2×11×24cm, 3.8kg

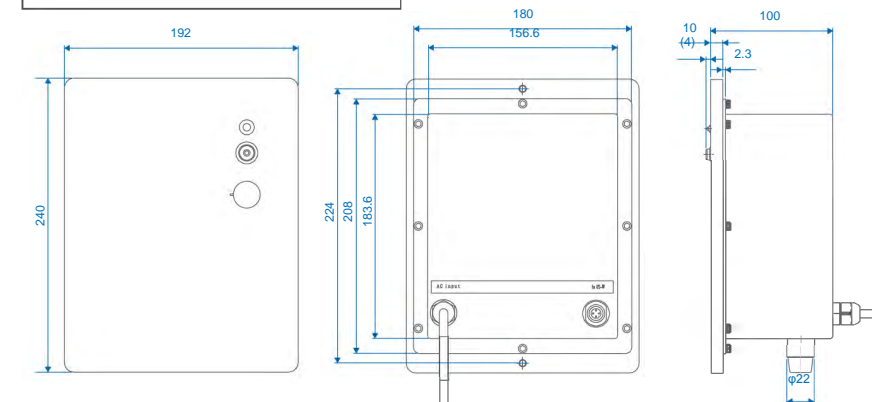

# CM™-BASEβ

PROFIBUS compatible IP64 water resistance



Materials in contact with the solution  
Prism: Sapphire  
Prism stage: Aluminum  
\*Uses Viton® o-rings.



### Lightweight body

Body materials are made with lightweight, durable aluminum, keeping costs down and making the unit even easier to use.



Due to high demand, this is a CM™-Baseα model that is modified to accommodate setup for tanks and pots.

### Specifications

Cat.No.	CM™-BASEβ 5851 CM™-BASEβ (M) 5852 CM™-BASEβ (L) 5853
Measurement items	Brix (temperature compensation according to sucrose)
Measurement range	0.0 to 93.0%
Resolution	0.1%
Measurement accuracy	±0.2%
Temperature compensation range	10 to 95°C
Measurement interval	Approximately 2 second/per. *Same with the output intervals.
Pressure resistance	5 to 40°C

### Power Supply and Output Method

Power supply : DC24V

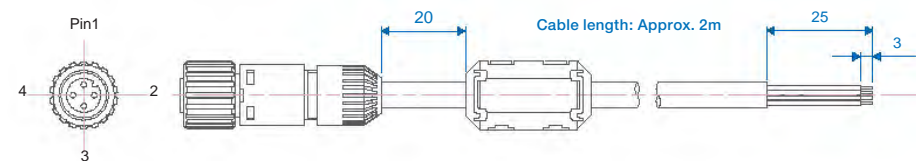

### Recorder output (DC4-20mA)

Brix values are output via DC4-20mA signals. Brix values ranging from -2.0 to 33.5% are communicated as DC ranging from 4 to 20mA, respectively. The cable can be extended to a custom length.

Pin No.	Cord color	Signalname	Pin No.	Cord color	Signalname
1	Red ●	DC24V input	3	Black ●	GND (DC24V)
4	Red / White ●○	DC4 to 20mA output	2	Black / White ●○	GND (DC4 to 20mA)

### RS-232C output

Brix values are output via RS-232C. The cable can be extended to a custom length of up to 15m.

Communications parameters	Baud rate: 2400bps Data length: 7bit	Parity: Even Stop bit: 1bit
Transmit data	Brix, temperature	Brix 19.5% Temp. 20.3°C

Pin No.	Cord color	Signalname	Pin No.	Cord color	Signalname
1	Red ●	DC24V input	3	Black ●	GND (DC24V)
4	Red / White ●○	RS-232C output	2	Black / White ●○	GND (RS-232C)

### Dimensions (unit of length: mm)

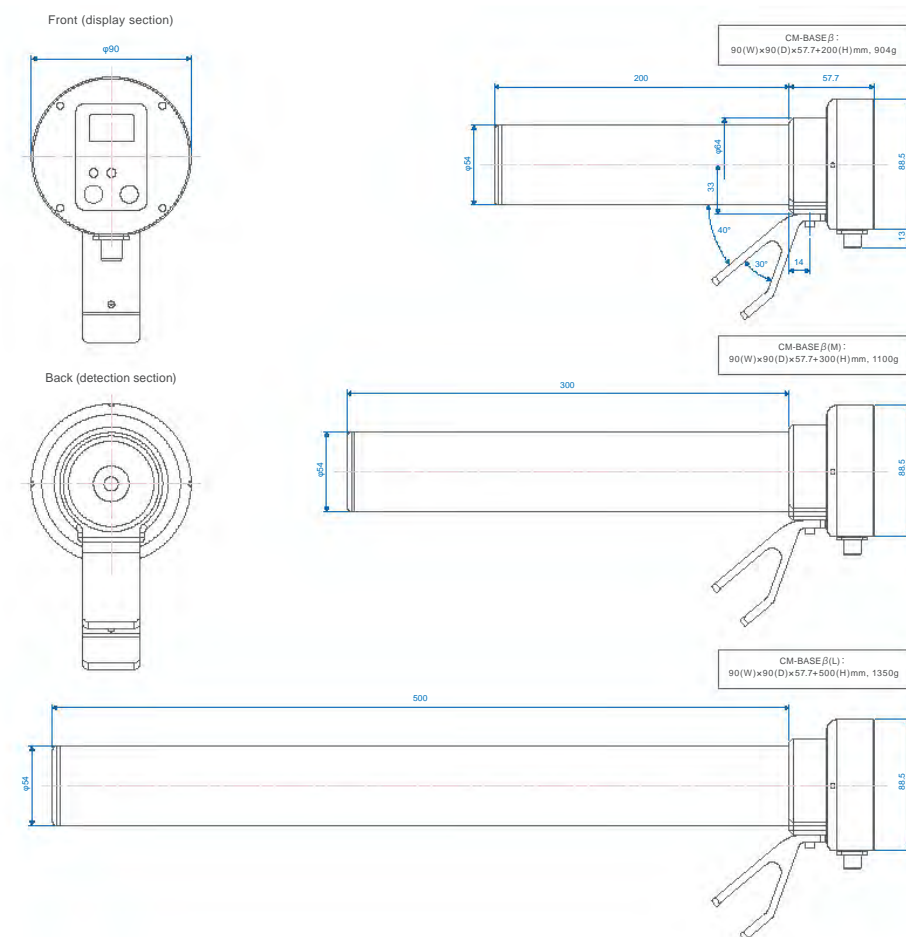

# PAN™-1DC



IP67  
water resistance  
Detection section

IP65  
water resistance  
Display section

## Rugged construction for reliable long-term performance!

The immersed part is made of SUS 316L stainless-steel.



Materials in contact with the solution  
Prism: Optical Glass  
Prism stage: SUS316L

\*As the prism is glass, a chemical resistance check is necessary.  
\*Uses Silicone and EPDM for o-rings.

No special installation necessary. Simply hook it on the edge of the tank or pot. Automatically measures approximately every 35 seconds repeatedly once the START button is pressed.

### Specifications

Cat.No.	PAN™-1DC : 3606 PAN™-1DC (M) : 3607 PAN™-1DC (L) : 3608
Measurement items	Brix (%), temp (°C)
Measurement range	Brix: 0.0 to 42.0% (ATC), temp: 10.0 to 99.9°C
Resolution	Brix: 0.1%, temp: 0.1°C
Measurement accuracy	Brix: ±0.2%, temp: ±0.5°C
Temperature compensation range	10 to 95°C
Measurement Interval	Automatic measurement once every 35 seconds.
Ambient temperature	10 to 45°C
Power consumption	0.6VA

### Power Supply and Output Method

Power supply : DC 24V (Allowable fluctuation is ±10%)  
Connecting the cable to the PAN™-1DC's connector located on the side provides power supply (DC24V) input, as well as Brix value output (via RS-232C). A cable with included connector is available as an optional accessory. The cable can be extended to a custom length of up to 15m. For details, please refer to pg. B52.

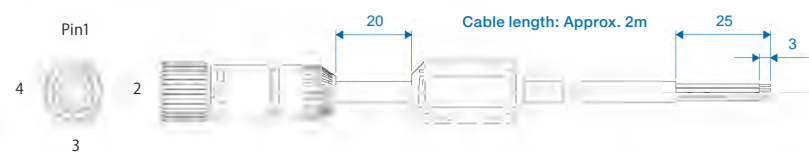

Pin No.	Cord color	Signalname
1	Red ●	DC24V input
2	Black / White ●○	GND (RS-232C)
3	Black ●	GND (DC24V)
4	Red / White ●○	RS-232C output

  

Communications parameters	Baud rate: 2400bps Data length: 8bit Parity: none Stop bit: 1bit	Transmit data	temperature, Brix Temp. 20.3°C Brix 19.5%	20.3, 19.5
---------------------------	---	---------------	---	------------

### Dimensions (unit of length: mm)

#### • Special Order Option •

The PAN™-1DC's rod length can be extended up to 120cm in 10cm increments. Contact ATAGO for details.

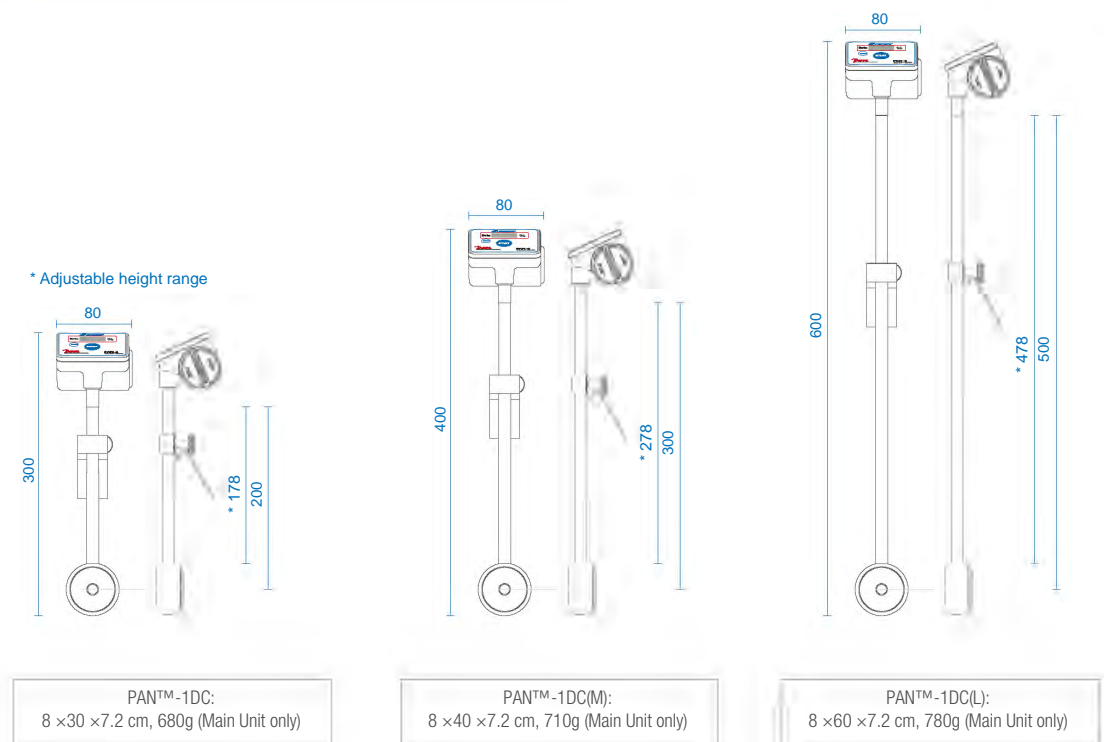

# PRM™-TANK100α DX(FER)

PROFIBUS compatible IP67 water resistance



Materials in contact with the solution  
Prism: Sapphire  
Prism stage: SUS316L

\*The packing is made by an excellent chemical resistance material.

## Connect directly to a tank

This model directly connects to a tank and measures the concentration inside the tank in real-time.



A model that can be directly installed into a tank via ferrule (3S). Continuously monitor the concentration with a measurement range of 0.00 to 100.00% Brix.

## Specifications

Cat.No.	3677
Measurement items	Refractive index (nD), Brix (temperature compensation according to sucrose), concentration (Conc) (User scale), and temperature (°C)
Measurement range	Refractive index (nD): 1.32000 to 1.55700, Brix: 0.00 to 100.00%, Temperature: -5.0 to 160.0°C
Resolution	① Refractive index (nD): 0.0001 Brix: 0.1% ② Refractive index (nD): 0.00001 Brix: 0.01%(Factory default setting) * by selection
Measurement accuracy	Refractive index (nD): ±0.00010 Brix: ±0.05% * When measuring standard solutions (sucrose) under stable temperature conditions.
Temperature compensation range	5 to 100°C
Alarm output	Open-collector output for high- and low-limit settings (alarm output).
Measurement interval	Approximately 1 measurement/second. *Same for output intervals.
Pressure resistance	0.98MPa (detection section)
Ambient temperature	5 to 40°C
Power consumption	30VA

## Output method

**RS-232C output**

**Recorder output (DC4-20mA)**

Calculation display section			D—Sub connector (PC side)		
Pin No.	Cord color	Signal name	Pin No.	Cord color	Signal name
1	Red ●	RXD	2	Red & White ●○	RXD
2	Red & White ●○	TXD	3	Red ●	TXD
3	Black ●	GND	5	Black ●	GND
			7	—	RTS
			8	—	CTS

Pin No.	Cord color	Signal name	Output
1	Red ●	Refractive Index (Brix, concentration) +	4 to 20mA
2	Black ●	Temperature +	4 to 20mA (-5 to 160°C)
3	Red & White ●○	Refractive Index (Brix, concentration)	4 to 20mA
4	Black & White ●○	Temperature -	4 to 20mA (-5 to 160°C)

## Dimensions (unit of length: mm)

Detection section: 10.8×17.26×10.8cm, 2.6kg (Excludes piping)

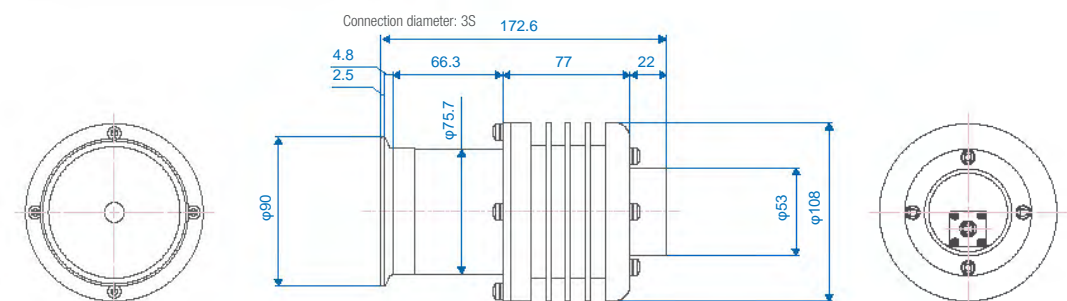

Power supply : AC100 to 240V, 50/60 Hz  
Cable : Detection section - Calculation display section (power supply 12V and RS-485) Length: standard 15m (maximum up to 200m)

Calculation display section: 19.2×10×24cm, 3.3kg

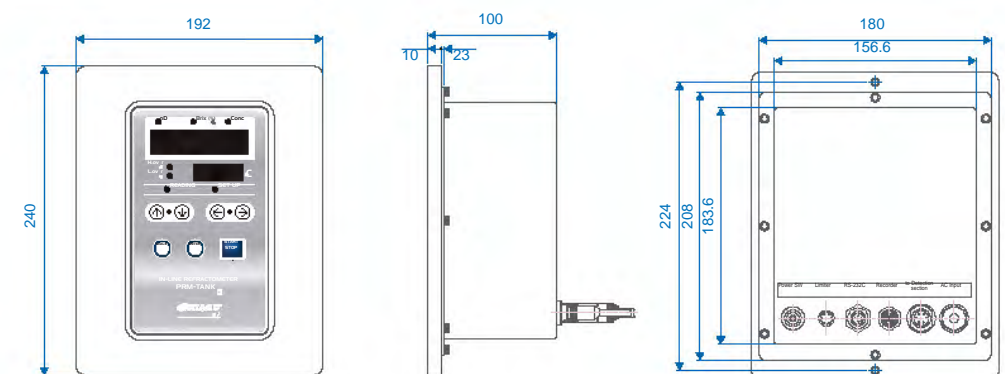

# PRM™-TANK2000α DX(FER)

PROFIBUS compatible IP67 water resistance



Materials in contact with the solution  
Prism: Sapphire  
Prism stage: SUS316L  
\*The packing is made by an excellent chemical resistance material.

## Connect directly to a tank

This model directly connects to a tank and measures the concentration inside the tank in real-time.



A model that can be directly installed into a tank via ferrule (3S). Continuously monitor the concentration with a measurement range of 0.000 to 20.000% Brix.

## Specifications

Cat.No.	3687
Measurement items	Refractive index (nD), Brix (Temperature compensation corresponding to 3 types of samples: sucrose, high-fructose corn syrup, and sugar-free beverages [2% or less]), concentration (Conc) (User scale), and temperature (°C).
Measurement range	Refractive index (nD): 1.32069 to 1.36500, Brix: 0.000 to 20.000%, Temperature: -35.0 to 165.0°C
Resolution	① Refractive index (nD): 0.00001 Brix: 0.001% (Factory default setting) ② Refractive index (nD): 0.00001 Brix: 0.005% ③ Refractive index (nD): 0.00001 Brix: 0.01% * by selection
Measurement accuracy	Refractive index (nD): ±0.00001 Brix: ±0.007% (Refractive index (nD): 1.32069 to 1.33681, Brix: 0.000 to 2.000%) Refractive index (nD): ±0.00010 Brix: ±0.050% (Refractive index (nD): from 1.33682 up, Brix: from 2.001% up)
Temperature compensation range	5 to 90°C
Alarm output	Open-collector output for high- and low-limit settings (alarm output).
Measurement interval	Approximately 1 measurement /second (factory default), 5 interval options. *Same for output intervals.
Pressure resistance	0.98MPa (detection section)
Ambient temperature	5 to 40°C
Power consumption	30VA

## Output method

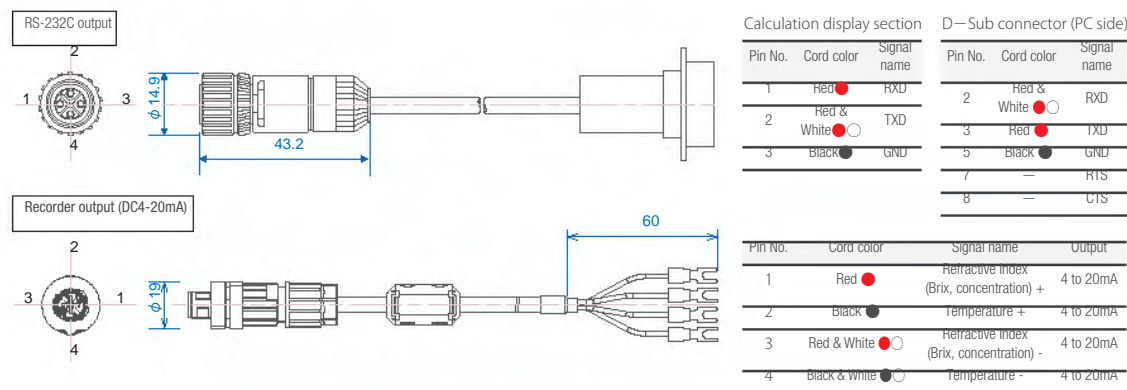

## Dimensions (unit of length: mm)

Detection section: 10.8×25.52×10.8cm, 3.2kg (Excludes piping)

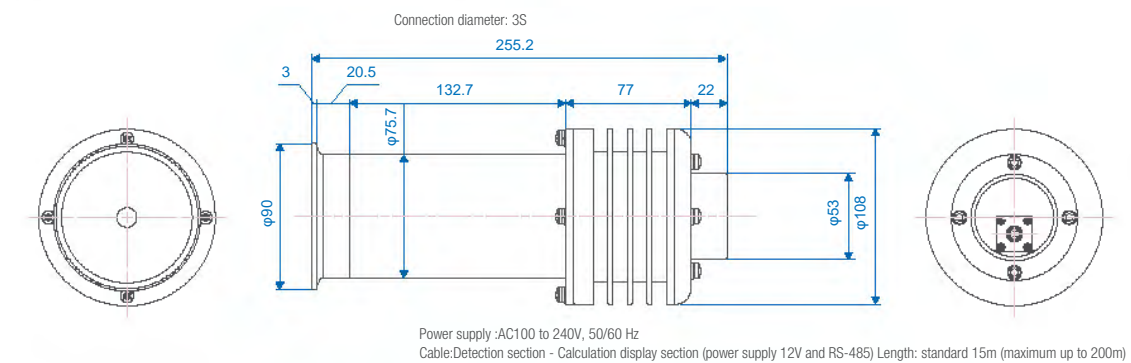

Calculation display section: 19.2×10×24cm, 3.3kg

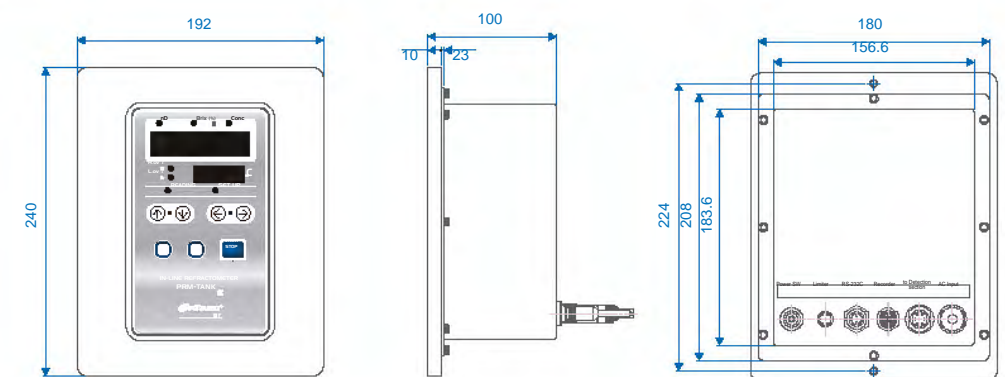

# PRM™-TANKα(FLN)



Materials in contact with the solution  
Prism: Sapphire  
Prism stage: SUS316L

\*The packing is made by an excellent chemical resistance material.



### Connect directly to a tank

This model directly connects to a tank and measures the concentration inside the tank in real-time.

A model that can be installed directly into the side of a tank. It can continuously monitor the concentration during extraction, boiling, mixing, fermentation, squeezing, and filtration with a range of 0.00 to 85.00% Brix. It is also recommended for tanks that handle chemicals.

### Specifications

Cat.No.	3575
Measurement items	Refractive index (nD), Brix (temperature compensation according to sucrose), concentration (Conc) (User scale), and temperature (°C)
Measurement range	Refractive index (nD): 1.31700 to 1.51000, Brix: 0.00 to 85.00%, Temperature: -5.0 to 110.0°C
Resolution	① Refractive index (nD) : 0.0001 Brix : 0.1 (Factory default setting) ② Refractive index (nD) : 0.00001 Brix : 0.01 * by selection
Measurement accuracy	Refractive index (nD) : ±0.0001 Brix : ±0.1% *When measuring standard solutions (sucrose) under stable temperature conditions.
Temperature compensation range	5 to 100°C
Alarm output	Open-collector output for high- and low-limit settings (alarm output).
Measurement interval	Approximately 1 measurement/second. *Same for output intervals.
Pressure resistance	0.98MPa (detection section)
Ambient temperature	5 to 40°C
Power consumption	30VA

### Output method

**RS-232C output**

Calculation display section			D— Sub connector (PC side)		
Pin No.	Cord color	Signal name	Pin No.	Cord color	Signal name
1	Red ●	RXD	2	Red & White ●○	RXD
2	Red & White ●○	TXD	3	Red ●	TXD
3	Black ●	GND	5	Black ●	GND
			7	—	RTS
			8	—	CTS

**Recorder output (DC4-20mA)**

Pin No.	Cord color	Signal name	Output
1	Red ●	Refractive Index (Brix, concentration) +	4 to 20mA
2	Black ●	temperature +	4 to 20mA (0 to 100°C)
3	Red & White ●○	Refractive Index (Brix, concentration) -	4 to 20mA
4	Black & White ●○	Temperature -	4 to 20mA (0 to 100°C)

### Dimensions (unit of length: mm)

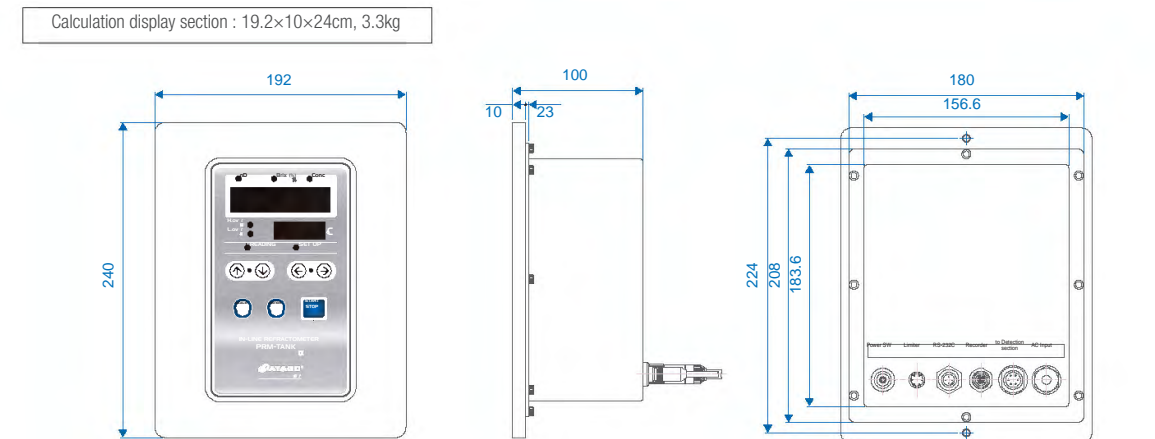
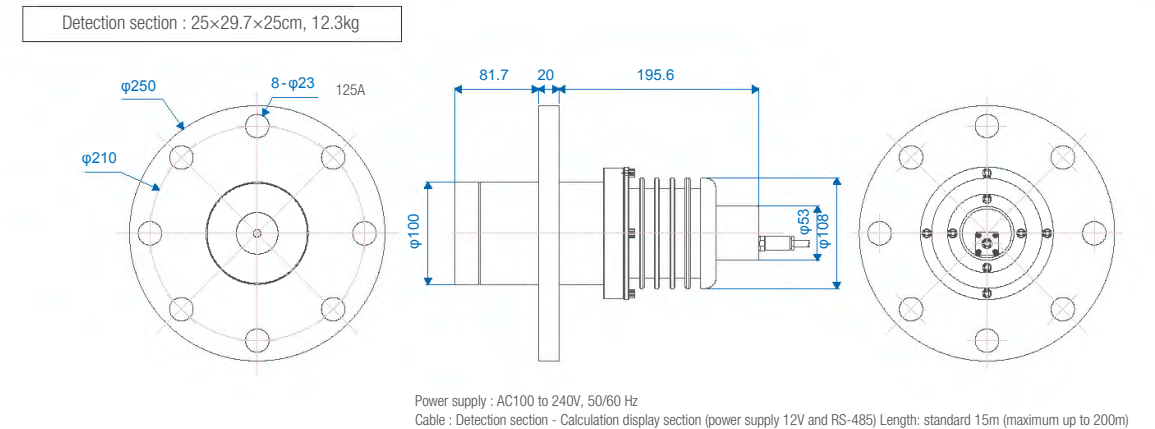

# CM™-TANKα(FER)



Materials in contact with the solution  
Prism: Sapphire  
Prism stage: SUS316L

\*The packing is made by an excellent chemical resistance material.

## Connect directly to a tank

This model directly connects to a tank and measures the concentration inside the tank in real-time.



One piece model that can be installed directly into a tank via ferrule (3S). It can continuously monitor the concentration with a range of 0.00 to 80.0% Brix.

## Specifications

Cat.No.	3567
Measurement items	Brix (ATC according to the sample liquid), Temperature (°C / °F)
Measurement range	Brix: 0.00 to 80.0%, Temperature: -15 to 160°C / 5 to 320°F
Resolution	Brix: 0.01 or 0.1% (With an option to display measurements between 0.00 and 9.99% to the 2nd decimal place.), Temperature: 1°C / 1°F
Measurement accuracy	Brix: ±0.1%, Temperature: ±1°C / ±1°F
Temperature compensation range	5 to 100°C
Measurement interval	Approximately 1 measurement /second (factory default), 5 interval options. *Same for output intervals.
Pressure resistance	0.98MPa
Ambient temperature	5 to 40°C
Power consumption	Power consumption when using DC24V: 3VA; when using AC100-240V: 15VA.

## Output method

Power supply : DC24V \* An optional accessory, "AC Adapter AD-32" is available to convert AC100V to DC24V.  
Refractive index output is standard with RS-232C; it is optional with recorder.

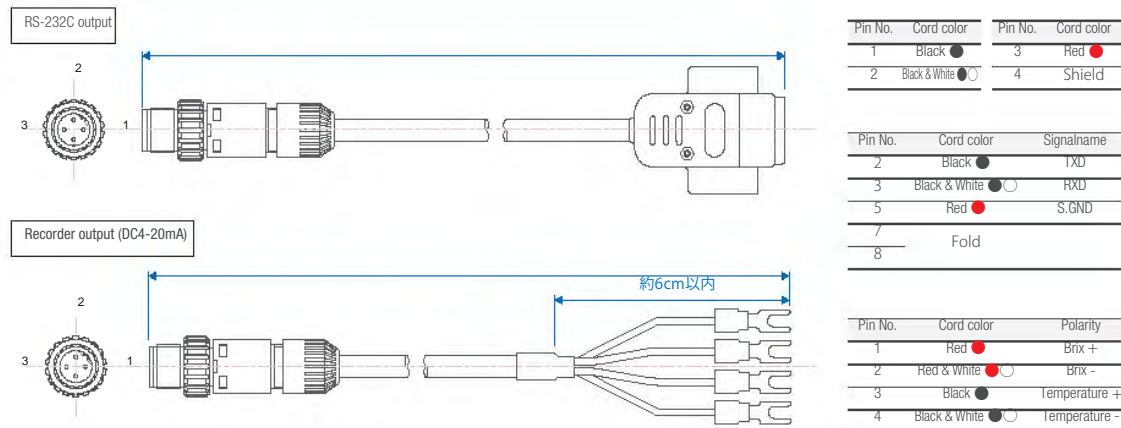

## Dimensions (unit of length: mm)

16×16.7×11cm, 2.4kg (Main Unit only)

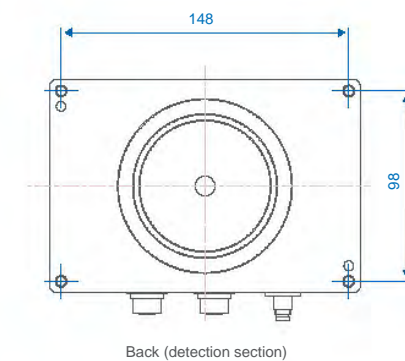
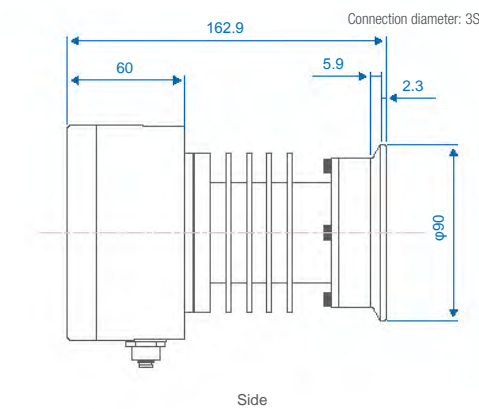
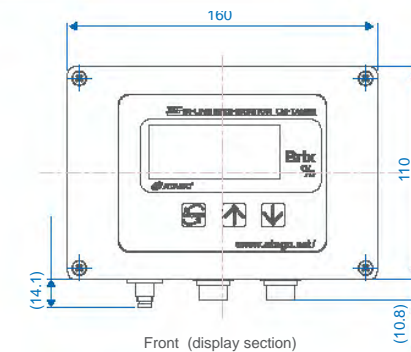

# CM™-TANKα-SW(FER)



Materials in contact with the solution  
Prism: Sapphire  
Prism stage: SUS316L

\*The packing is made by an excellent chemical resistance material.

## Connect directly to a tank

This model directly connects to a tank and measures the concentration inside the tank in real-time.



One piece model that can be installed directly into a tank via ferrule (3S). It can continuously monitor the concentration with a range of 0.00 to 28.0% Salinity.

## Specifications

Cat.No.	3701
Measurement items	① Salinity (ATC according to the sample liquid), ② Temperature (°C / °F)
Measurement range	① 0.00 to 28.0%, ② -15 to 160°C / 5 to 320°F
Resolution	① 0.01 or 0.1% (With an option to display measurements between 0.00 and 9.99% to the 2nd decimal place.), ② 1°C / 1°F
Measurement accuracy	① ±0.1%, ② ±1°C / ±1°F
Temperature compensation range	5 to 100°C
Measurement interval	Approximately 1 measurement /second (factory default), 5 interval options. *Same for output intervals.
Pressure resistance	0.98MPa
Ambient temperature	5 to 40°C
Power consumption	Power consumption when using DC24V: 3VA; when using AC100-240V: 15VA.

## Output method

Power supply : DC24V \* An optional accessory, "AC Adapter AD-32" is available to convert AC100V to DC24V.  
Refractive index output is standard with RS-232C; it is optional with recorder.

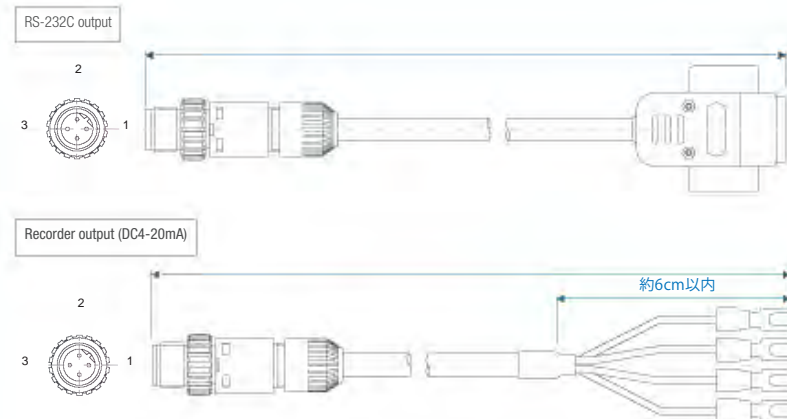

Pin No.	Cord color	Pin No.	Cord color
1	Black ●	3	Red ●
2	Black & White ●○	4	Shield

Pin No.	Cord color	Signalname
2	Black ●	TXD
3	Black & White ●○	RXD
5	Red ●	S.GND
7		
8	Fold	

Pin No.	Cord color	Polarity
1	Red ●	Brix +
2	Red & White ●○	Brix -
3	Black ●	Temperature +
4	Black & White ●○	Temperature -

## Dimensions (unit of length: mm)

16×16.7×11cm, 2.4kg (Main Unit only)

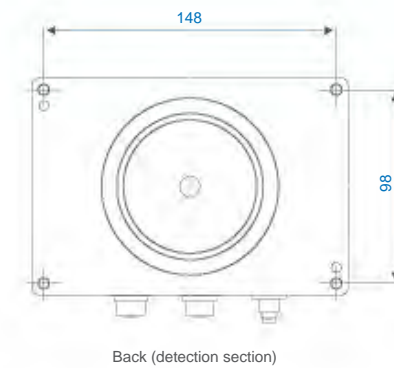
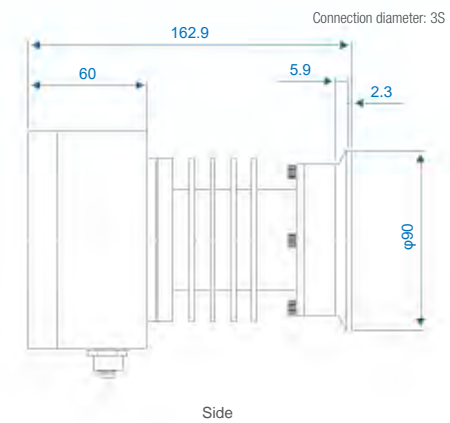
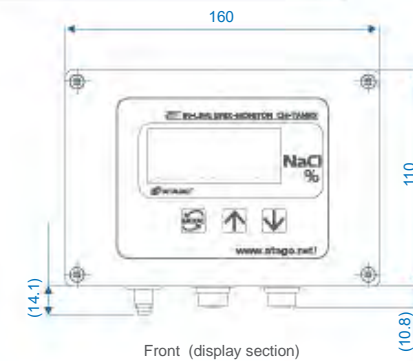

# CM™-TANKα-Urea(FER)

PROFIBUS compatible IP67 water resistance



Materials in contact with the solution  
Prism: Sapphire  
Prism stage: SUS316L

\*The packing is made by an excellent chemical resistance material.

## Connect directly to a tank

This model directly connects to a tank and measures the concentration inside the tank in real-time.



One piece model that can be installed directly into a tank via ferrule (3S). It can continuously monitor the concentration with a range of 0.0 to 55.0% Urea water.

## Specifications

Cat.No.	3718
Measurement items	① Urea(Adblue) (ATC according to the sample liquid), ② Temperature (°C / °F)
Measurement range	① 0.0 to 55.0%, ② -15 to 160°C / 5 to 320°F
Resolution	① 0.1%, ② 1°C / 1°F
Measurement accuracy	① ±0.3%, ② ±1°C / ±1°F
Temperature compensation range	10 to 100°C
Measurement interval	Approximately 1 measurement /second (factory default), 5 interval options. *Same for output intervals.
Pressure resistance	0.98MPa
Ambient temperature	5 to 40°C
Power consumption	Power consumption when using DC24V: 3VA; when using AC100-240V: 15VA.

## Output method

Power supply : DC24V \* An optional accessory, "AC Adapter AD-32" is available to convert AC100V to DC24V.  
Refractive index output is standard with RS-232C; it is optional with recorder.

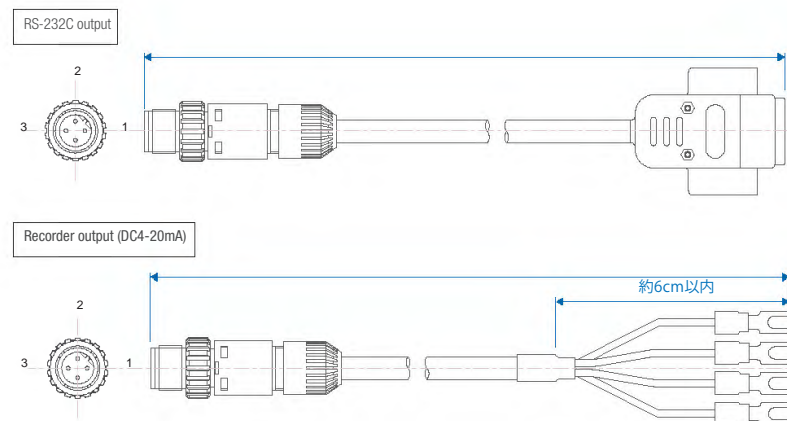

Pin No.	Cord color	Pin No.	Cord color
1	Black ●	3	Red ●
2	Black & White ●○	4	Shield

Pin No.	Cord color	Signalname
2	Black ●	TXD
3	Black & White ●○	RXD
5	Red ●	S.GND
7		
8	Fold	

Pin No.	Cord color	Polarity
1	Red ●	Brix +
2	Red & White ●○	Brix -
3	Black ●	Temperature +
4	Black & White ●○	Temperature -

## Dimensions (unit of length: mm)

16×16.7×11cm, 2.4kg (Main Unit only)

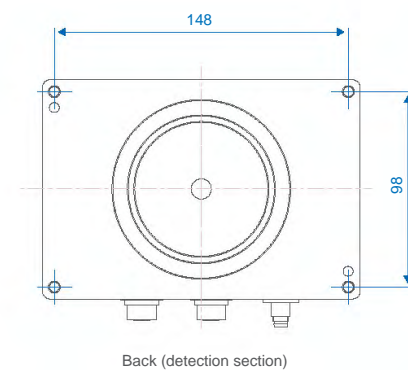
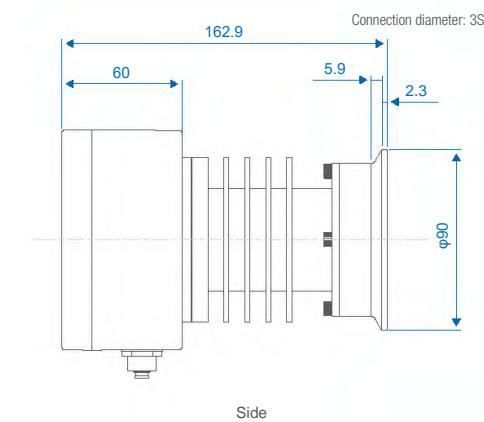
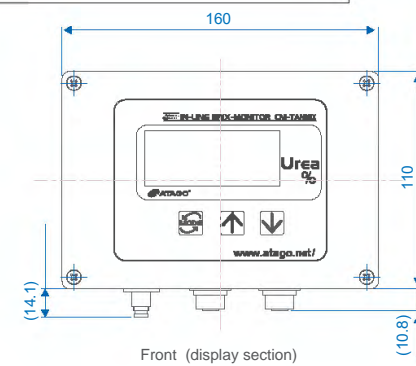

# CM™-INTANK



Materials in contact with the solution  
Prism: Sapphire  
Prism stage: SUS316L

### Suspend it in a tank

Using the grooves on the CM-INTANK, attach a chain, etc., and suspend the unit in the tank.



Use underwater. Designed to be water resistant up to 5m and withstand water pressure(0.3MPa) at 30m. Once powered on, it will take measurements approximately every 2 seconds without any further operation on the main unit.

### Specifications

Cat.No.	① CM™-INTANK (A) 3617 ② CM™-INTANK (D) 3627
Measurement items	Brix (temperature compensation according to sucrose)
Measurement range	0.0 to 33.0%
Resolution	0.1%
Measurement accuracy	±0.5%
Temperature compensation range	10 to 40°C
Measurement Interval	Approximately 2 second/per. *Same with the output intervals.
Pressure resistance	0.98MPa
Ambient temperature	10 to 40°C

### Power and Output Method

Power supply : DC24V

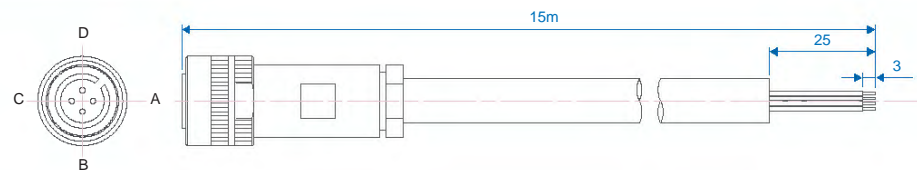

#### CM™-INTANK(A)

Brix values are output via DC4-20mA signals. Brix values ranging from -2.0 to 33.5% are communicated as DC ranging from 4 to 20mA, respectively.

Pin No.	Cord color	Signalname	Pin No.	Cord color	Signalname
A	Red ●	DC24V	C	Black ●	DC24V GND
B	White ○	DC4 to 20mA GND	D	Green ●	DC4 to 20mA

#### CM™-INTANK(D)

Brix values are output via RS-232C.

Communications parameters	Baud rate: 2400bps Data length: 7bit	Parity: Even Stop bit: 1bit
Transmit data	Brix,temperature	Brix 19.5% Temp. 20.3°C

Pin No.	Cord color	Signalname	Pin No.	Cord color	Signalname
A	Red ●	DC24V	C	Black ●	DC24V GND
B	White ○	RS-232C GND	D	Green ●	RS-232C

### Dimensions (unit of length: mm)

φ10×8.56cm, 2.5kg (Main Unit only)

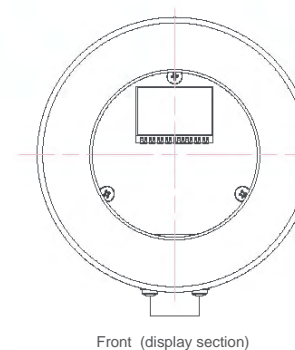
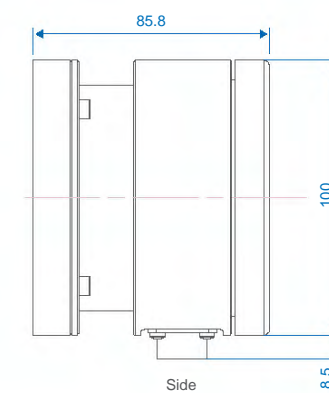
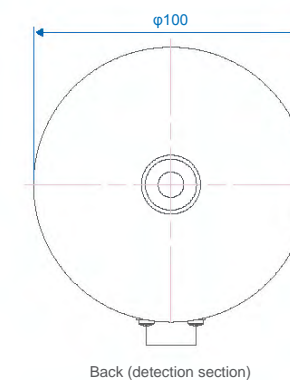

## Optional Accessories



[Mounted Example]

### Stand for CM™-800α

RE-8607

The picture on the left is an example of the actual in-line Brix monitor (CM™-800α) and the AC adapter, AD-32 mounted on the stand.



### Stand for CM™-BASEα

RE-67690

This is a stand for CM™-BASEα that makes on-site installation easier.



### Bracket for CM™-BASEα

RE-67691

This is a bracket for CM™-BASEα that can be installed in any direction, up, down, left, or right.

Parts No.	Name	Notes	Applicable Models
RE-65385	Recorder Output Cable With 1 Connector(5m)	5m	Same as CM™α series
RE-65386	Recorder Output Cable With 1 Connector(10m)	10m	Same as CM™α series
RE-65387	Recorder Output Cable With 1 Connector(15m)	15m	Same as CM™α series
RE-65388	Recorder Output Cable With 1 Connector(20m)	20m	Same as CM™α series
RE-65389	Recorder Output Cable With 1 Connector	Length customizable within 15m	Same as CM™-α series
RE-65332	RS-232C Output Cable With Connector D-sub 25pin	15m	Same as CM™-α series
RE-65333	RS-232C Output Cable With Connector D-sub 25pin	Length customizable within 15m	Same as CM™-α series
RE-65334	RS-232C Output Cable With Connector D-sub 9pin	15m	Same as CM™-α series
RE-65335	RS-232C Output Cable With Connector D-sub 9pin	Length customizable within 15m	Same as CM™-α series
RE-65301	RS-232C output cable with 25 pin D-sub connector	Standard length: 10m; can be extended in increments of 1m.	Same as PRM™α series
RE-65305	Alarm Output Cable	Standard length: 10m	Same as PRM™α series
RE-65303	Recorder output cable	Standard length: 10m; can be extended in increments of 1m.	Same as PRM™α series
RE-65311	Detection - Calculation Display Connecting Cable	Standard length: 15m; can be extended in increments of 1m.	Same as PRM™α series
RE-65115	Cable for CM™-BASE	Standard length: 2m; can be extended in increments of 1m.	CM™-BASEα-β series
RE-75101	Power and RS-232C(9pins) cable with AC adapter	Standard 2m. Up to 15m for a custom length.	PAN™-1 DC
RE-65111	Cable for CM™-INTANK	15m	CM™-INTANK

## Adhesion prevention series — Consistently protects the sensor area from adhesion



### US-α™

RE-Cat.No.9113-00 US-α™(1S)  
RE-Cat.No.9113-01 US-α™(2S)  
RE-Cat.No.9113-02 US-α™(3S)

The US-α prevents debris from adhering to the prism surface of the PRM™-100α, PRM™-2000α and CM™-800α. As with other fittings, it can be affixed in the piping system. For details, refer to pg. B42.



[Mounted Example]

### Ultra -Easy Prism Wiper

RE-67594

The photo on the left is an example of Ultra-Easy Prism Wiper attached to the concentration monitor body. For details, refer to pg. B13.

(For CM™α series and PRM™α series)



### Manual Prism Wiper

RE-67590 For straight piping

Compatible with: 1S to 3S  
Compatible with: 20A to 6A  
For details, refer to pg. B9.



### Hose connector with prism wiper

RE-67508 Hose Connector(Outer diameter: 12mmΦ) with Manual Prism Wiper  
RE-67591 Hose Connector(Outer diameter: 12mmΦ) with Manual Prism Wiper (without buffing)  
RE-67509 Compression Fitting 10mmΦ with Manual Prism Wiper  
RE-67592 Compression Fitting 10mmΦ with Manual Prism Wiper (without buffing)

A hose connector with a manual prism wiper. Refer to pg. B67 for without a manual prism wiper. (For CM™α series and PRM™α series)

Parts No.	Name	Notes	Applicable Models
RE-69114	Desiccant(30g)	For internal protection of detection section	Same as PRM™α series
RE-68100	O-Ring for between Sample inlet and Detection Unit(Silicon)	O-ring used for the detection section and sample inlet.	CM™α series-PRM™α series
RE-8507	Tube Band (A Set of 10 PCS.)	10 qty	For hose connector

Special Order

# Customizable Wetted Part

Custom orders available. Contact ATAGO for further details.

## SUS(standard specification)



Stainless steel with high strength and excellent corrosion resistance. Sanitary specification.

## Titanium



Metal with high strength, light weight, corrosion resistance, heat resistance. In particular, it has higher corrosion resistance to salt than the stainless steel.

## Hastelloy



Alloy with high corrosion resistance and heat resistance. Especially, it is resistant to hydrochloric acid and sulfuric acid, and it is corrosion resistant even at high temperature.

\* Hastelloy is a trademark of Haines Corporation, USA.



PRM™ series



CM™-800 series



CM™-BASE series



TANK series

\*Excludes PAN-1DC

# Detection Section Installation Example

Install sample inlet and detection section as shown below.

## Products (Ferrule)

- PRM™-100α DX
- PRM™-2000q DX
- CM™-800α series
- CM™-BASEα
- PRM™-TANKα DX(FER)
- CM™-TANKα(FER)

## Installation Method

Straight Ferrule with blanking plate Example: CM™-800α

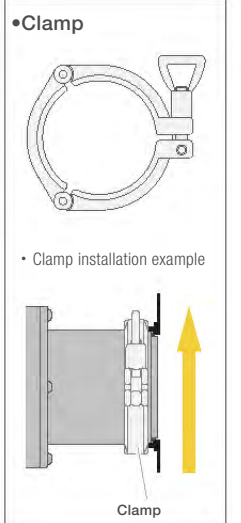
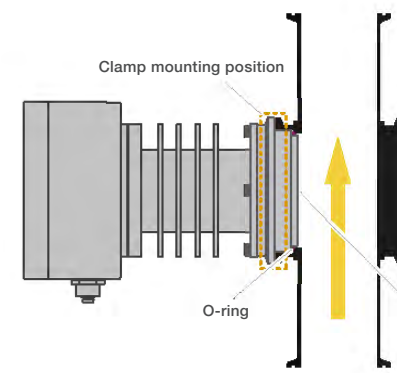

※ Direction of sample flow

Hose connector Example: CM™-BASEα

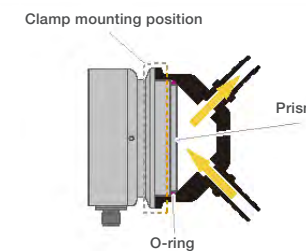

Tank installation Example: PRM™-TANKα DX(FER)

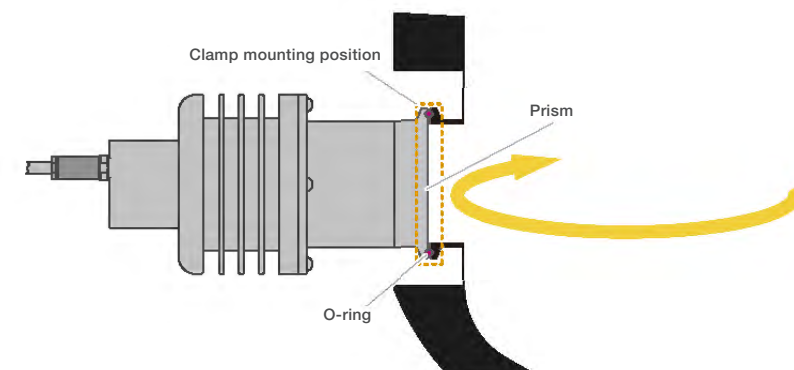

# Sample Inlets

# Sample Inlet List

Fittings that meet VARIVENT standards are also available. For details, please contact ATAGO.

## Fitting Sizes List

IDF/JIS G3447 (ferrule and screw)			JIS G3459 (flange)		
Size	Outer diameter	Inner diameter	Size	Outer diameter	Inner diameter
1.0S	25.4	23.0	20A	27.2	23.0
1.25S	31.8	29.4	25A	34.0	28.4
1.5S	38.1	35.7	32A	42.7	37.1
2.0S	50.8	47.8	40A	48.6	43.0
2.5S	63.5	59.5	50A	60.5	54.9
3.0S	76.3	72.3	65A	76.3	70.3
3.5S	89.1	85.1	80A	89.1	83.1
4.0S	101.6	97.6	90A	101.6	95.6
4.5S	114.3	108.3	100A	114.3	108.3

(Unit of length: mm)

## Attachment Methods

### Correct

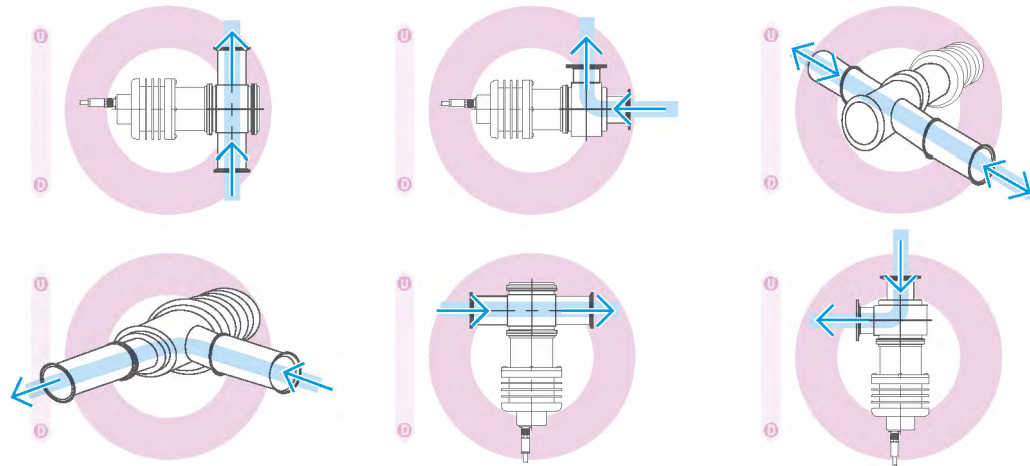

### Incorrect

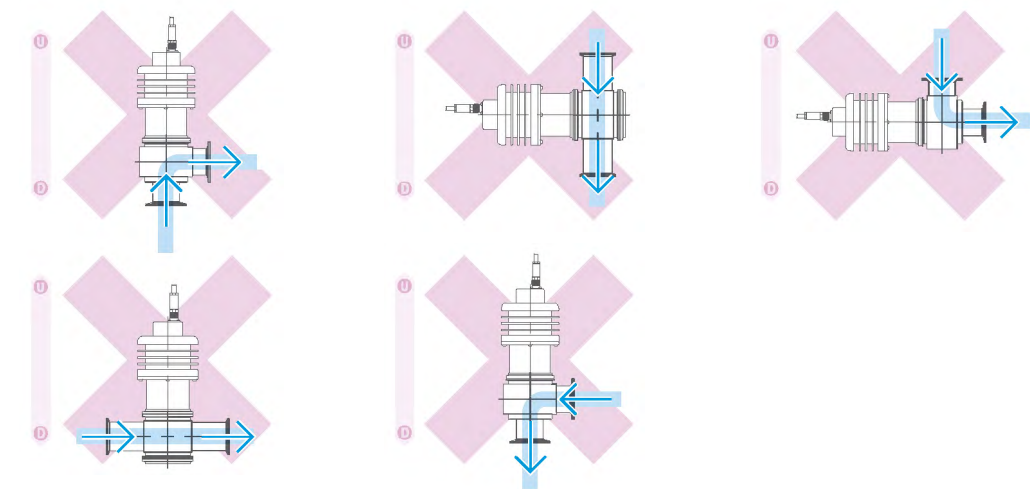

RE No.	Name	Simplified Dimensions	Connection Example (PRM™-100a DX)
RE-67501	Hose connector φ12mm		
RE-67503	DBJ φ10mm		
RE-67511	Straight type ferrule 1S with blanking plate		
RE-67513	Straight type screw 1S with blanking plate		
RE-67611	L type ferrule 1S		
RE-67613	L type screw 1S		
RE-67512	Straight type ferrule 1.5S with blanking plate		
RE-67521	Straight type ferrule 2S with blanking plate		

\* Fittings are generally sold with an in-line refractometer as a set. If you wish to purchase fittings only, please consult ATAGO.

RE No.	Name	Simplified Dimensions	Connection Example (PRM™-100a DX)
RE-67523	Straight type screw 2S with blanking plate		
RE-67621	L type ferrule 2S		
RE-67623	L type screw 2S		
RE-67522	Straight type ferrule 2.5S with blanking plate		
RE-67531	Straight type ferrule 3S with blanking plate		
RE-67533	Straight type screw 3S with blanking plate		
RE-67631	L type ferrule 3S		
RE-67633	L type screw 3S		
RE-67570	Straight type flange 25A with blanking plate		

\* Fittings are generally sold with an in-line refractometer as a set. If you wish to purchase fittings only, please consult ATAGO.

RE No.	Name	Simplified Dimensions	Connection Example (PRM™-100a DX)
RE-67671	L type flange 25A		
RE-67574	Straight type flange 40A with blanking plate		
RE-67673	L type flange 40A		
RE-67576	Straight type flange 50A with blanking plate		
RE-67526	Straight type flange 65A with blanking plate		
RE-67675	L type flange 65A		
RE-67583	Straight type flange 80A with blanking plate		
RE-67578	Straight type flange 100A with blanking plate		

\* Fittings are generally sold with an in-line refractometer as a set. If you wish to purchase fittings only, please consult ATAGO.

In-line Refractometer Guide



# 16 Applications

A Deep & Entertaining Discussion  
About In-line Refractometers

## The Complete In-line Refractometer Guide!

**A Comprehensive Collection of 16 Applications**

Everything from canned coffee, beer, and other beverages, the food industry, industrial applications such as syrups, to wastewater—all 16 applications collected in one book!

**The Definitive In-line Refractometer Guide!**

This guidebook is the bible of selecting in-line refractometers. You will soon know everything you need to know about in-line refractometers.

# Contents

## In-line Refractometer Guide 16 Applications

### In-line Applications

- |                                      |  |
|--------------------------------------|--|
| <b>A4</b> Beverages                  | <b>A12</b> Vinegar                                   |
| <b>A5</b> Coffee • Tea               | <b>A13</b> Wastewater /<br>Effluent Water            |
| <b>A6</b> Beer                       | <b>A14</b> Surface Treatment Agents                  |
| <b>A7</b> Gelatin &<br>Gummy Candies | <b>A15</b> DMF • DMAC • DMSO                         |
| <b>A8</b> Soy Milk & Tofu            | <b>A16</b> White Mold Release Agent                  |
| <b>A9</b> Tomato Purée               | <b>A17</b> Hydrogen Peroxide and<br>Sodium Hydroxide |
| <b>A10</b> Ketchup                   | <b>A18</b> Resists                                   |
| <b>A11</b> Brine                     | <b>A19</b> Plating Solutions<br>(Sulfuric Acid)      |

All ATAGO products are designed and manufactured in Japan.

**ATAGO CO.,LTD.**  
<https://www.atago.net/>

Headquarters: The Front Tower Shiba Koen, 23rd Floor  
2-6-3 Shiba-koen, Minato-ku, Tokyo 105-0011, Japan  
TEL : 81-3-3431-1943 FAX : 81-3-3431-1945



**HACCP GMP GLP**  
ATAGO products comply with HACCP,GMP,  
and GLP system standards.

**ATAGO U.S.A., Inc.**  
**ATAGO INDIA Instruments Pvt.Ltd.**  
**ATAGO THAILAND Co.,Ltd.**  
**ATAGO BRASIL, Ltda.**  
**ATAGO ITALIA s.r.l.**  
**ATAGO CHINA Shanghai Co.,Ltd.**  
**ATAGO RUSSIA Ltd.**  
**ATAGO KAZAKHSTAN Ltd.**

TEL : 1-425-637-2107  
TEL : 91-22-28544915, 40713232  
TEL : 66-21948727-9  
TEL : 55 16 3913-8400  
TEL : 39 02 36557267  
TEL : 86-20-38108256  
TEL : 7-812-777-96-96  
TEL : 7-727-257-08-95

customerservice@atago-usa.com  
customerservice@atago-india.com  
customerservice@atago-thailand.com  
customerservice@atago-brasil.com  
customerservice@atago-italia.com  
info@atago-china.com  
info@atago-russia.com  
info@atago-kazakhstan.com

\* Specifications and appearance are subject to change without notice.

Copyright © 2024 ATAGO CO., LTD. All rights reserved. 2402700GR

# Beverages

Fruit juice, carbonated beverages, sports drinks, Flavored beverages

There are many varieties of drinks that come to mind when it comes to "beverages." With the exception of tea and sports drinks, on the whole, beverages contain about 10g of sugar per 100g.

Sugar level, as well as concentration (Brix) can be measured with in-line refractometers.

In-line meters are used to provide measurements on samples in blending equipment that mix raw materials and water, as well as a pass/fail check for products before filling.



## Case Study

Raw ingredients

Blending

Pasteurization

Bottling

Packaging

### Mixing Ratio Feedback System

In real time, measure mixing ratio and respond by changing flow volume adjustment.

### Pre-Bottling Final Check

A final check on the product before bottling is made to make sure it is within specifications. Controlling the switch between various liquids can help reduce liquid loss.

**For carbonated beverages** When adding carbonation before filling, the concentration can be controlled once the carbonation is added.

**Brix example**  
Sport drinks usually measure about 6% Brix.

Recommended Products



PRM™-100α DX  
B22



PRM™-2000α DX  
B24

And more

**Check for liquid switch** When switching to a new liquid on the production line, the concentration can be checked for whether or not it has been changed.

**Cleaning Solution Concentration Check** Used to monitor appropriate concentration level of the caustic soda or peracetic acid used to sanitize the piping system.

# Coffee • Tea

coffee milk, Tea

It is said that Japan is the largest consumer of canned coffee, but the aspect foreigners find most surprising is the high-level quality of its taste.

There are an abundance of varieties, and what's more, they preserve that high-quality taste with a flavor that is on par with freshly brewed coffee.

Japanese canned coffee manufacturers are in constant pursuit of that delectable flavor, and to maintain that same tastiness, in-line refractometers are used at many stages in the process.

Currently, all kinds of means are used to strengthen canned coffee's brand image and increase recognition, such as creating and instilling the brand with a high-end, elite quality.



## Case Study

Raw ingredients

Grinding

Extraction

Blending

Bottling

Sterilization

Inspection and Packaging

### Concentration measurement prior to mixing

Manage extraction yield by measuring the Brix of the extracted solution. Depending on the extraction yield, extraction is repeated.

### Mixing Ratio Feedback System

In real time, measure mixing ratio and respond by changing flow volume adjustment. help reduce liquid loss.

### Pre-Bottling Final Check

A final check on the product before bottling is made to make sure it is within specifications. Controlling the switch between various liquids can help reduce liquid loss.

**Brix example**  
Tea drinks (no added sugar) 0.2 to 0.5% Brix.

Recommended Products



PRM™-2000α  
B24



PRM™-TANK100α DX(FER)  
B48

And more

**Check for liquid switch** When switching to a new liquid on the production line, the concentration can be checked for whether or not it has been changed.

**Cleaning Solution Concentration Check** Used to monitor appropriate concentration level of the caustic soda or peracetic acid used to sanitize the piping system.

# Beer

Composed of raw ingredients such as malt derived from sprouted barley, hops, brewer's yeast, and water, beer is universally cherished for that distinct aroma of its hops and that cool, refreshing, fizzy feeling produced by its carbonation.

Beer is divided into different categories such as top-fermenting ales and bottom-fermenting lagers, depending on the brewing method and the type of yeast.

Generally speaking, the flavor of "beer" greatly differs, depending on the brewing method.

Perhaps such vast flavor variety is the connection to beer's long-standing appeal.



## Case Study

Malting

Preparation

Fermentation

Fermentation tank

Filtration

Bottling

Inspection and Packaging

### Wort Concentration Control

Wort, the source of beer, is measured most commonly during the boiling process.

### Fermentation Process Management

During fermentation, yeast converts most of the sugar in the wort to alcohol and carbon dioxide gas. Brix is used to determine when to stop the alcohol fermentation process.

### Pre-Bottling Final Check

A final check on the product before bottling is made to make sure it is within specifications. Controlling the switch between various liquids can help reduce liquid loss.

**Brix example** Beer measures about 4 to 5% Brix.

Recommended Products



For any requests for measurements other than concentration, such as CO2, please contact ATAGO.

And more

**Check for liquid switch** When switching to a new liquid on the production line, the concentration can be checked for whether or not it has been changed.

**Cleaning Solution Concentration Check** Used to monitor appropriate concentration level of the caustic soda or peracetic acid used to sanitize the piping system.

# Gelatin & Gummy Candies

Imagine the sound of quivering gelatin, "wibbly wobbly, jiggly wiggly." Gelatin comes in many forms, from a confectionery made to be an easily ingested food with highly beneficial nutrients, to a stewed, jellied dish as a cuisine.

Originally, it is a confectionery made from a combination of fruit juice, gelatin, and sugar.

Variations are made by adding other ingredients such as fruit, spices, and acidulants.

Jelly beans, gummy candies and the like are foods made from processed gelatin.



## Case Study

Raw ingredients

Blending

Sterilization

Bottling

Sterilization

Cooling

Shipping

### Mixing Ratio Feedback System

In real time, measure mixing ratio and respond by changing flow volume adjustment.

**Concentrate status check**

For gummy candy: Concentration is checked when mixing the raw materials, heating up the slurry, and concentrating.

### Pre-Bottling Final Check

A final check on the product before bottling is made to make sure it is within specifications. Controlling the switch between various liquids can help reduce liquid loss.

Jello is around 15 to 20% Brix while gummies are closer to 80% Brix.

And more

**Check for liquid switch** When switching to a new liquid on the production line, the concentration can be checked for whether or not it has been changed.

**Cleaning Solution Concentration Check** Used to monitor appropriate concentration level of the caustic soda or peracetic acid used to sanitize the piping system.

Recommended Products



PRM™-100α DX B22 CM™-TANKα B54

# Soy Milk & Tofu

Tofu contains many necessary nutrients for us humans, while soy milk is liquid produced when soy beans are boiled and crushed. The protein in soymilk is said to be nutritious and of a high quality. In fact, the beautifying effects of the isoflavones in soy beans are famous.

To produce tofu, soy beans are soaked in water for a time and then, while adding more water, the beans are grounded to make a paste (Namago). This paste is then boiled and strained, separating it into soy milk and "okara", or bean curd. Bittern (a coagulant) is added to the soy milk which turns it into tofu and of course frying this creates fried tofu.



## Case Study (Soy Milk)

Raw ingredients

Submerge and Soak · Grind

Boil · Separate

Blending

Sterilization

Bottling

Cooling and Shipping

### Concentration measurement of Namago (bean paste)

Namago (bean paste) can vary in concentration depending on the amount of moisture soy bean contains and how much water is absorbed during the soaking process. The concentration is adjusted by adding water depending on its hardness.

#### Point

Soy milk can be categorized to non-adjusted, prepared soy milk, and soy milk beverages depending on the amount of soy that remains as solids. This makes the monitoring of the soy concentration to be one of the important factors to manage.

### Mixing Ratio Feedback System

In real time, measure mixing ratio and respond by changing flow volume adjustment.

### Pre-Bottling Final Check

A final check on the product before bottling is made to make sure it is within specifications. Controlling the switch between various liquids can help reduce liquid loss.

#### Recommended Products



PRM™-100α DX B22



PRM™-2000α DX B24

#### Scales

Available in a soy milk solids content special scale. Contact ATAGO for further information.

#### And more

**Check for liquid switch** When switching to a new liquid on the production line, the concentration can be checked for whether or not it has been changed.

**Cleaning Solution Concentration Check** Used to monitor appropriate concentration level of the caustic soda or peracetic acid used to sanitize the piping system.

# Tomato Puree

Tomatoes are a vegetable with such great nutritional value that it can almost be said that, "even malnourished people become robust and their strength improves when it's tomato ripening season."

This physically revitalizing appeal which is recognized all over the world, is certainly attributed to their high nutritional value.

Moreover, people may find tomatoes' exquisite balance of sweetness and sourness to be simply irresistible to their taste buds.

Tomato purée is a concentrate made by crushing tomatoes and straining them through a sieve. It is also used as a raw ingredient for ketchup.



## Case Study

Raw ingredients

Crushing and pre-heating

Straining

Concentration

Bottling

Sterilization

Cooling and Shipping

### Concentration measurement of pre-blending solution

Check that the tomato juice concentration (Brix) made from raw materials is within specifications.

### Concentrate status check

Used to check the concentration.

#### Brix example

For tomato purees, unsalted soluble solids must be no less than 8% but under 24%. When it is further concentrated, and soluble solids become greater than 24%, it is called tomato paste.

A final check on the product before bottling is made to make sure it is within specifications. Controlling the switch between various liquids can help reduce liquid loss.

#### And more

**Check for liquid switch** When switching to a new liquid on the production line, the concentration can be checked for whether or not it has been changed.

**Cleaning Solution Concentration Check** Used to monitor appropriate concentration level of the caustic soda or peracetic acid used to sanitize the piping system.

#### Recommended Products



PRM™-100α DX B22



CM™-800α B26

# Ketchup

Ketchup is made by adding onion, carrot and other savory fragrant vegetable broth and flavorings such as herbs, spices, salt, sugar, and vinegar to tomato purée (tomato concentrate) and heating it to concentrate.

Ketchup's sweetness, sourness, and saltiness influence the flavor of cuisine, and its thickness can influence how well ingredients mingle together in dishes such as pasta.

This is why the extent to which ketchup is boiled down is extremely important.

In-lines are used to preserve this crucial flavor.



## Case Study

tomato purée

Pre-heating

Straining

Blending

Homogenization and mixing

Concentration

Sterilization

Bottling

Sterilization and Shipping

### Mixing Ratio Feedback System

In real time, measure mixing ratio and respond by changing flow volume adjustment.

### Concentrate status check

Used to check the concentration.

**Brix example** For tomato ketchup, soluble solids must be greater than or equal to 25%. When soluble solids are more than 8% but less than 25%, it is called tomato sauce.

### Pre-Bottling Final Check

A final check on the product before bottling is made to make sure it is within specifications. Controlling the switch between various liquids can help reduce liquid loss.

Recommended Products



PRM™-100α DX  
B22



CM™-800α  
B26

And more

**Check for liquid switch** When switching to a new liquid on the production line, the concentration can be checked for whether or not it has been changed.

**Cleaning Solution Concentration Check** Used to monitor appropriate concentration level of the caustic soda or peracetic acid used to sanitize the piping system.

# Brine

Essential for fisheries, pasta, instant ramen noodles and more!

An overabundant intake of salt is linked to a risk of lifestyle diseases such as high blood pressure and heart disease.

From a different aspect, salt plays an important part in our bodies. Salt has a role in adjusting the amount of moisture of our bodies; chlorine, which is composed of salt, is the primary component of stomach acid and supports digestion, and within saliva, salt enlivens the function of digestive fluids.

Such is the vital role salt plays as a necessity for life. However, still more, in terms of taste perception, insufficient salt leads to bland dishes that fall short on flavor. Salt is a crucial element in expertly drawing out the flavor of ingredients.



## Case Study (Small White Sardines)

Raw ingredients

Washing

Boiling in a pot with high temperature brine

Cooling

drying

Foreign substance removal

Shipping

### Concentration control of boiled cooking water

Shirasu (small white sardines) must be treated immediately as it does not remain fresh for long. The boiling water to cook shirasu is kept at 80°C in a hot pot with salinity at about 3.5%. During the boiling process, the salt is added to compensate for the loss caused by evaporation and salt that gets absorbed in shirasu.

Even in the manufacturing process of cup ramen, the concentration of saline solution mixed in the noodles is controlled by an in-line refractometer that is directly attached to the tank.

Recommended Products



CM™-800α  
B26



CM™-BASEα-03S  
B40

And more

**Cleaning Solution Concentration Check** Used to monitor appropriate concentration level of the caustic soda or peracetic acid used to sanitize the piping system.

# Vinegar



Vinegar is said to be quite good for the body. There are many kinds of vinegar such as grain vinegar made from rice, wheat, corn, and the like, and fruit vinegar made from fruits. Although vinegar is a type of liquid seasoning, it has countless beneficial effects including constipation relief, high blood pressure prevention, appetite stimulation, fatigue alleviation, and anti-microbial effects. Recently, there has been an increase in products that are easier to adopt into our lifestyle, such as drinking vinegars (shrubs).

## Case Study

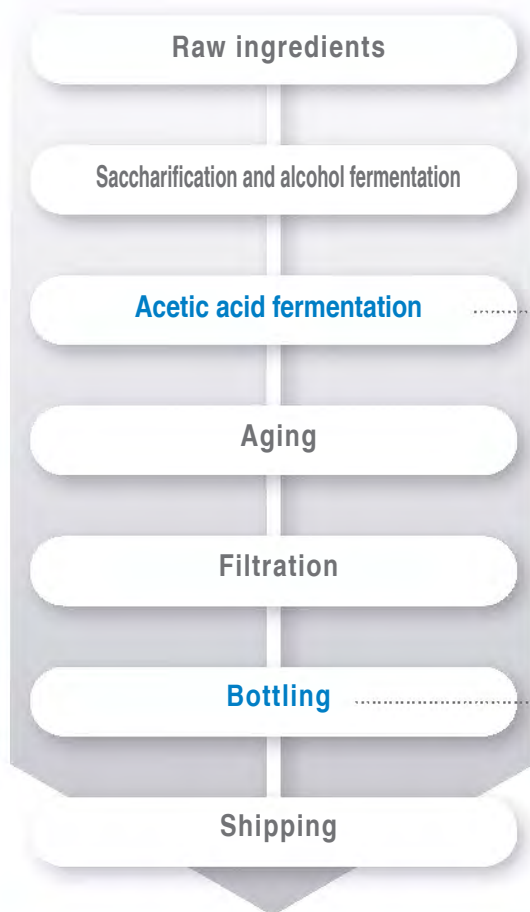

### Fermentation Process Management

The progress and condition of acetic acid fermentation can be checked.

**About vinegar** The Japanese Agricultural Standard (JAS), "Consumable Vinegar Japan Agricultural Standards" defines vinegars to be made by brewing grains or fruits and then adding acetobacter to facilitate fermentation.

### Pre-Bottling Final Check

A final check on the product before bottling is made to make sure it is within specifications. Controlling the switch between various liquids can help reduce liquid loss.

**Recommended Products**

**Available in Different Materials** Vinegars can be very acidic and corrode metals, but the material can be switched something more durable, such as titanium. Contact ATAGO for further information.

**And more**

**Check for liquid switch** When switching to a new liquid on the production line, the concentration can be checked for whether or not it has been changed.

**Cleaning Solution Concentration Check** Used to monitor appropriate concentration level of the caustic soda or peracetic acid used to sanitize the piping system.

# Wastewater / Effluent Water



It goes without saying that manufacturing products will produce wastewater. In food manufacturing related industries, there are waste fluids produced when refining sugar and manufacturing beverages, as well as waste fluids from cleaning solutions.

On the self-governing level and such, manufacturers independently establish safety standards for waste fluid. Harmful waste fluids and high concentration wastewater effects the ecosystem and its potentially detrimental effects on our bodies cannot be ignored.

## Case Study



### Wastewater Concentration Pre-Check

Detect when an unexpected solution is mixed into wastewater.

### Wastewater Concentration Pre-Check

Check ahead of time whether the concentration is appropriate for discharge to the aeration tank. If the concentration is too high, it will exceed the treatment capability. In such cases, wastewater is diluted by adding water.

### Prevent high concentration wastewater discharge

Even in cases where the organic matter in wastewater is not completely decomposed, by monitoring and detecting the concentration of wastewater more than usual discharge of high-concentration wastewater can be prevented.

**Recommended Products**

# Surface Treatment Agents

"Surface treatment" refers to a physical and chemical treatment applied to the surface of solid materials for aesthetic, ornamental, hardening, and enhanced corrosion resistance purposes.

Types of treatments include cleaning, polishing, etching, and coating, but to demonstrate the maximum effectiveness of surface treatment, it must be performed with the same, standard concentration.

Therefore, using in-line refractometers to check whether the concentration is as usual is immensely important.



# DMF • DMAC • DMSO

DMF : Dimethylformamide

DMAC:Dimethylacetamide

DMSO: Dimethylsulfoxide

These are widely used as solvents.

Dimethylformamide (DMF) may be unfamiliar name but it is very much used in the acrylic fiber forming and as a solvent for wet spinning. It is also used as a solvent for artificial leather and urethane-based synthetic leather.



## Case Study

### Degreasing

#### Concentration Control of Degreasing Solution

It is important to monitor the concentration as it becomes contaminated over time.

\*Contact ATAGO for explosion proof models.

### Rinsing

#### Concentration Monitoring For Rinse Water

Measures concentration of the rinse water used to wash chemical agents.

### Surface conditioning

#### Maintaining Proper Concentration

Concentration of surfactant solutions lowers over time. No need to use other analyzers such as HPLC, etc.

### Rinsing

### Chemical conversion

#### Recommended Products



**Introducing US-α** Some types of surfactant are more likely to adhere to the detection section. In such cases, we recommend using the US-α™ to prevent buildup.

**Contact ATAGO for more information** ATAGO is experienced with surfactants concentration management. For further details, contact ATAGO.

### Post-treatment coating (e.g. oil)

## Case Study (Artificial Leather Processing)

### Non-Woven Fabric

### Impregnation

### Coagulation Tank

#### DMF Concentration Check

DMF is used as a solvent for polyurethane in the production of artificial leather. First, a non-woven fabric is impregnated with a water-based aqueous solution containing a surfactant. Then, it is dipped in a DMF solution in a coagulation bath to undergo urethane formation reaction. Since the DMF solution in the coagulation bath is gradually diluted with water from the previous step, the concentration control of the DMF aqueous solution is important because its quality affects the concentration. The DMF solution in the coagulation process is recycled through the recovery system, and in some cases, a refractometer is built into the recovery system. The method of producing artificial leather varies depending on the application, and a DMF solution may be used in the impregnation process.

**Case** DMF is also used in the manufacturing process of rubber gloves. An in-line meter is installed in the wash tank concentration to ensure that DMF has been removed completely in the final wash process to monitor concentration. For an environmental and health standpoint as well, it is important to measure and monitor numerically whether the removal is complete.

### Washing

#### Recommended Products



### Drying

# White Mold Release Agent



In the process of making products such as cast-metal objects (casting), a chemical called a "release agent" is used to aid in smoothly and easily removing the product from the mold.

There are many advantages in managing the concentration of release agents.

If the concentration is low, product defects can occur, such as color stains on the product, or a section of the cast-metal object may chip off. If the concentration is high, de-molding can become difficult, requiring force to remove the product from the mold, which can warp the product. By managing the concentration of release agents, in conjunction with preventing defective products and errors, productivity can be improved.

## Case Study

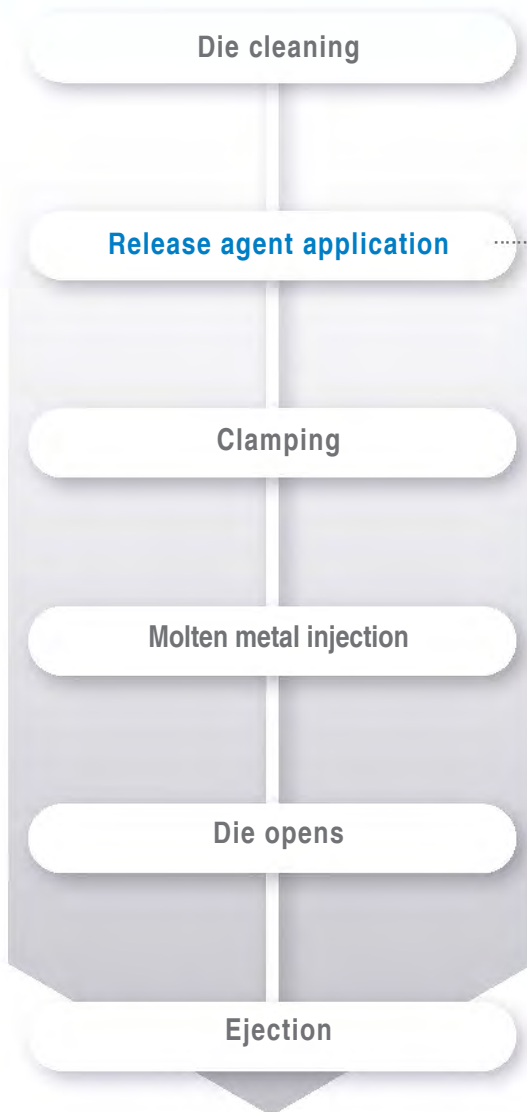

### Maintaining Proper Concentration

Measure the concentration of liquid agents to maintain consistent levels.

**Case** At a site where a casting mold release agent is managed by an in-line meter, it is a semi-automated process, where an alarm lamp will light to notify the workers of any abnormalities. With the introduction of in-line meters, it is possible to check numerical values and receive alarms without requiring the workers to be onsite. It will contribute to improve and detect lot errors caused by mold not separating properly.

**Case** At a location where it is installed as a sensor on a mold release agent mixing and delivery system, it is used for the concentration control of the collection and recovery of the mold release agent after use and the flow of metal before flowing into the mold. In the past, conductivity meters were used, but because of the high maintenance due to deposits accumulating on the electrode, refractometers are now installed.



Using PAL portable refractometer along with in-line units will allow for easy cross-checking.

# Hydrogen Peroxide and Sodium Hydroxide



In modern Japan, many aseptically packaged products are used. A sterile filling and packaging system that makes it possible to preserve food such as milk, other dairy products, dessert, soft drinks, and highly viscous, liquid foods for a long time has been established. Many kinds of containers are used in this process; paper containers, glass, bottles, cans, plastic containers, PET bottles, and others.

For example, in the bottling process of beverage production, a low concentration of hydrogen peroxide is sprayed inside a paper carton to sterilize it. At this point, it is necessary to use in-line refractometers to manage the optimal concentration for sterilization.

## Case Study (Sterilization)

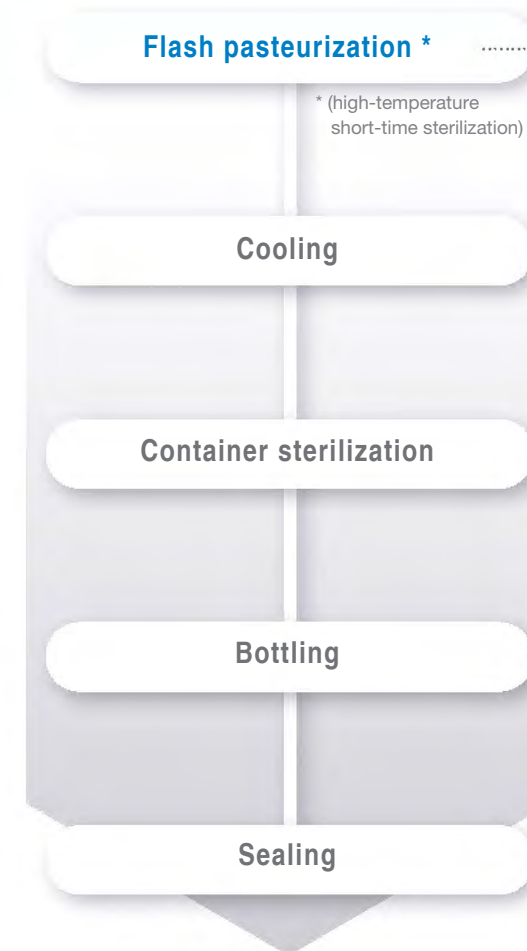

### Concentration monitoring of Sterilization Solution

In order to maintain consistency, the concentration of sterilization solution is measured. If the concentration is too high, it remains in the paper packaging, and if it is too low, the effect of sterilization will diminish. Beverage manufacturers are continually improving quality control measures to ensure that consumers receive safe products.

**Case** One beverage manufacturer uses 35% hydrogen peroxide solution to clean paper packaging materials. In-line is installed to check the concentration change while using the same liquid for a week. Besides hydrogen peroxide solution, caustic soda may be used as a sterilizing solution.

**Case** Another beverage manufacturer installed an in-line meter to measure caustic soda concentration (about 50%) used to wash beverage production lines. Here, the concentration the beverage itself can also be measured by an in-line refractometer.



### And more

**Check for liquid switch** The water is flushed when switching from the disinfectant to a beverage, but this can be confirmed by checking if the concentration is zero.

# Resists

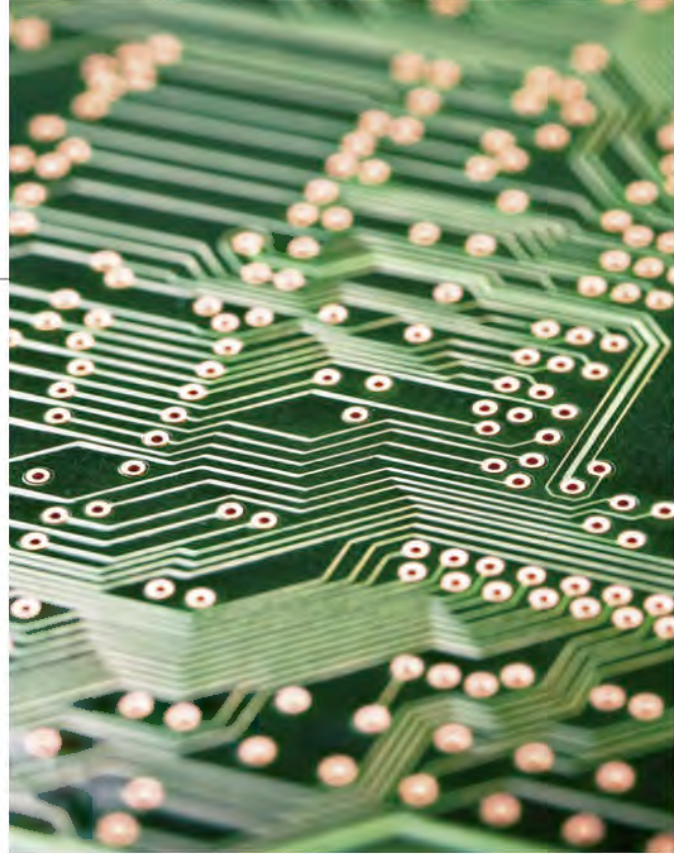

Resists are rarely seen directly in our daily lives. Nonetheless, they are used in many familiar, common, places such as on top of electronic PCBs and semi-conductors which power electronic and electrical products, LCDs (liquid crystal), and printed materials. Resists are absolutely invaluable to items that are closely tied to our modern lives such PC and tablet monitors, and LCD TVs. This market continues to develop every day.

## Case Study

Pre-treatment

Resist coating

Exposure · Development

Etching

Ejection

Washing

### Concentration Monitoring by Application

**Knowledge** It is mainly applied for the purpose of protective film and short circuit fault prevention. The green colored films are known for protecting the substrate, but in fact there are various types. The color used as resist variations and are not only for design purposes, but also have practical applications such as hiding the wiring of the board and making the circuit design hidden.

**Knowledge** It is also used for the purpose of improving image quality by highly controlling the cell gap of LCD as a photo spacer required for liquid crystal. For example, when a resist is used as a spacer for advanced control, highly advanced = thickness is precisely controlled for graphical quality, thickness = concentration control by in-line meters.

**Recommended Products**

PRM™-100α DX  
B22

CM™-800α  
B26

# Plating Solutions (Sulfuric Acid)



Plating is widely used in familiar, everyday items such as in smartphones and tablets, PCs, automobiles, and accessories. "Mekki" is the Japanese word for plating. Although the term may seem like it originated from a foreign loanword, mekki is actually Japanese in origin. Plating has an unexpectedly long history. Overseas, it has been used since the BC era, and in Japan, it has also been used since long ago, from the Kofun period. Plating has many expansive roles such as improving appearance, corrosion resistance, and abrasion resistance, and for function and performance. Just as plating serves many purposes, there are also many kinds of plating techniques.

## Case Study (Sterilization)

Degreasing

Acid Cleaning

Surface Activity

Metal Plating

Post-Processing

Drying

Concentration of sulfuric acid used in the plating solution is controlled. By controlling the process and adjusting the components, the plating solution can remain stable and it can keep finished products more consistent.

**Comparison With Other Principles** Alternatively, using conductivity meters instead of in-line refractometers is an option. Some customers prefer refractometers for safety reasons and to avoid troublesome sensor replacement.

**Recommended Products**

CM™-800α  
B26

**Available in Different Materials** When measuring sulfuric acid, chemical compatibility with the wetted part may be a concern. Contact ATAGO for information about different material types available.